

LUX ELEMENTS – The Experience
Shower bases





Welcome to LUX ELEMENTS

True to our motto, 'Solutions for modern building design', our medium-sized family business based in Leverkusen, Germany, has been producing hard foam support elements for moist and wet areas for more than three decades. Founded back in 1945 as a tiling company, we have based our development of this modern building material on the practical experience we have gained processing tiles every day.

Our range of products extends from construction panels and standardised system building kits to constructions for wellness and bathing environments. A main item in the product range are the tileable shower bases including drainage technology in the TUB product group. These products have been continuously developed and improved over the last 20 years.



LUX ELEMENTS – The Experience

Content

Solutions for modern building design

Bathroom planning: modern – design-oriented – functional – barrier-free	4
High material quality and environmentally-friendly production	6
The shower experience with flush with the floor shower bases	8
Tileable shower bases for every bathroom	10

LUX ELEMENTS®-TUB

The system for point and linear drainage	12
Shower trays for universal use	22
The flexible variant	24
Shower bases for the substitution of bath tubs	26
Shower bases for the use on wooden sub-constructions	28
The extra-slim solution for renovation of old buildings	30
Further areas of application	34
Ensures drainage under soft floor coverings	34
The first flush with the floor shower base which pumps itself	36
Shower drain element with integrated wall drain	38
Programme summary	40

Technology and processing tips

Drain technology and compatible accessories	48
Installation heights	50
Drainage capacity	55
Tile covering – surface covering thicknesses and height adjustment	56
Processing – Tools and assembly KITS	58
LUX ELEMENTS®-System components – seals and adhesives	59
Sealing of the shower area	60
Optional accessories	62

Bathroom planning

modern - design-oriented - functional - barrier-free



LUX ELEMENTS – Solutions for modern building design



Trend toward greater comfort

Today, bathrooms play a central role in daily life. The trend toward a conscious sense of well-being and toward relaxation in one's own four walls leads to higher demands on the design and furnishing of a bathroom. Right at the top of the list of wants: high-quality, individual fittings to suit one's personal taste.

New ways in old buildings

A dream bathroom can become reality even in an old building: with materials that are so light that they can be transported without effort to the fifth floor even without a lift. With prefabricated components that can be assembled particularly quickly. And with extra-slim shower bases that guarantee showering pleasure without tripping hazards, even with low installation heights.

Freedom from barriers in the bathroom: functionality and design are not mutually exclusive

Modern bathroom planning means thinking about tomorrow today. The cross-generational bathroom should be functional and practical, without tripping hazards or barriers. How fortunate it is that these wishes can be combined with contemporary design! For example with flush with the floor showers and self-supporting washstands. Safe, convenient and particularly chic!



Register-Nr.
P1B036 und P1B037

Hard foam support elements

High material quality and environmentally-friendly production

The basic material for the flush with the floor shower bases of LUX ELEMENTS is LUX ELEMENTS®-FOAM, a very high-quality, blue coloured, expanded polystyrene hard foam with high density that is produced using an environmentally friendly technique without foaming agents which are harmful to the climate. The moisture-resistant material is ideally suitable for use in bathrooms.

During further processing, the hard foam becomes a hard foam support element with a special mortar coating on both sides. For increased rigidity values a glass-fibre fabric is additionally embedded in the mortar coating. The hard foam support shower bases finally receive a sealing on the top side from the factory.

No chance for mould – biological behaviour

LUX ELEMENTS®-FOAM does not provide a breeding ground for micro-organisms. It does not rot or get mouldy. FOAM is neither harmful to the environment nor hazardous to water.

The safety of FOAM is made most obvious by the fact that the same raw-material is used to make food packaging. In its composition, the EPS FOAM fulfils the recommendation V polystyrene of the German Federal Health Office.



“The Original - LUX ELEMENTS®
hard foam support element” -
this pioneering invention in tiling
was patented 1981 by Herbert Lux.

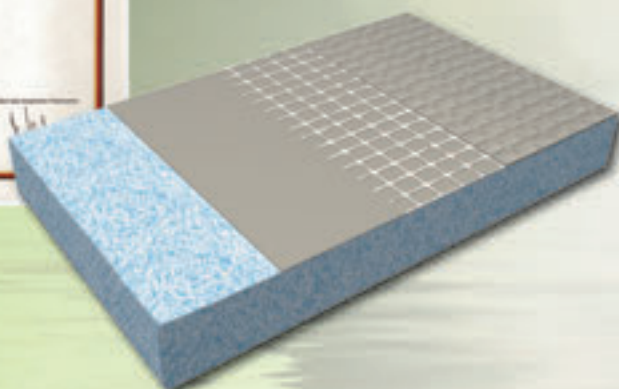

Proven material advantages

The original can do!

Hard foam support elements from LUX ELEMENTS are characterised by particular material properties, which are of particular advantage for use in wet and humid conditions.



■ environmentally friendly



■ proven quality

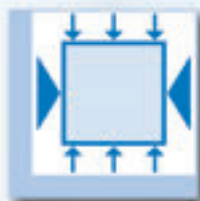

■ pressure-stable and rigid



■ lightweight



■ waterproof



■ fire-retarding



■ insulating



■ mould-resistant



■ design variety



■ alternative surfaces



■ economical



■ system-oriented

Since 1981, hard foam support elements from LUX ELEMENTS have been successful in practical use and have proved themselves there to this day. As a modern building material, the ORIGINAL must fulfil high requirements. This includes always meeting current technical standards and trends and being flexible. This is why we place great importance on continuous development of the ORIGINAL and the extension of a modern, system-oriented product range.

Would you like
to learn more?



Please see:

www.the-original-can-do.com



LLLLLLLLL
LLLLLLLLL
LLLLLLLLL
LUX ELEMENTS®
LLLLLLLLL

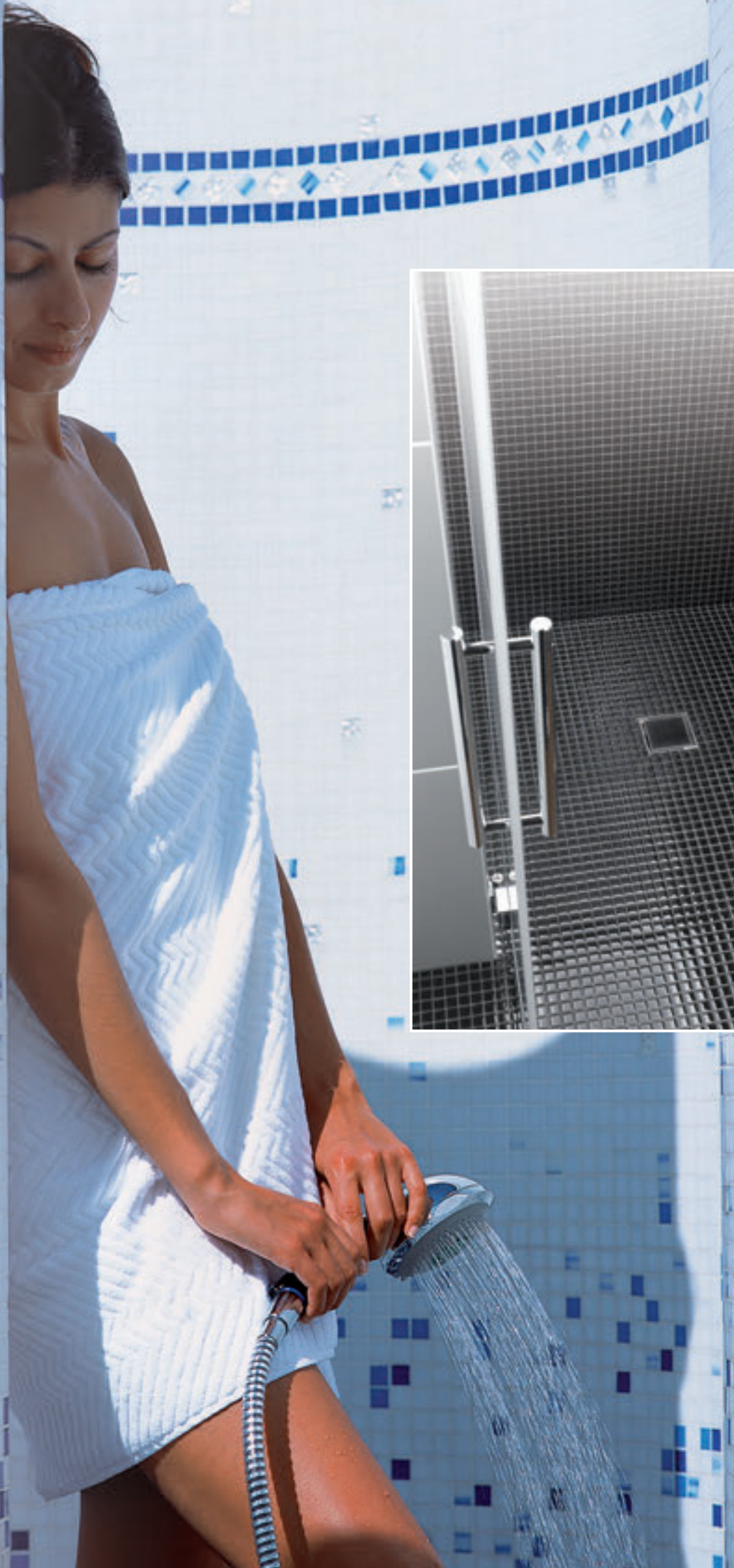

LUX ELEMENTS – The Experience

Shower bases

The shower experience with flush with the floor shower bases

Anyone planning a shower today barely thinks of a conventional shower base. Neither in a new building nor when refurbishing. The new terms for modern and contemporary products are flush floor, no-threshold and barrier-free.

When selecting a competent manufacturer, it is important to find one who is acquainted with the technology and offers reliable products.

LUX ELEMENTS looks back on more than 20 years of experience in the development and production of flush with the floor shower bases. Our products are the result of practical knowledge and continuous research.

Advantages of flush with the floor showers

- There is no tripping hazard and therefore they are easily accessible for young and old alike.
- Flush with the floor showers are modern and make the bathroom appear more attractive.
- They enable a homogenous floor covering and integrate the shower area into the room. This makes the bathroom appear to be larger.
- One advantage that should not be underestimated is the easy cleaning and care.
- In public sanitary areas, recreation and sports facilities, hotels or hospitals, barrier-free shower bases comply with standards or are even specified. The LUX ELEMENTS shower bases $\geq 120 \times 120$ cm and $\geq 150 \times 150$ cm are certified according to the appropriate standards.





Shower bases made from hard foam support material offer many advantages as opposed to products from other materials such as e.g. acrylic or enamelled steel. Apart from the light weight, which facilitates transport and processing and the ease of workability, the advantages lie particularly in the freedom of design.

As the products are finally tiled, there are versatile options. The selection of ceramics from mosaic to natural stone, the colours and the laying pattern ensure individual design, adapted to the floor covering or remaining design of the bathroom.

At the same time the walking safety can be influenced by selecting non-slip floor coverings. This way, taking a shower is a safe experience!

LUX ELEMENTS – The Experience

Shower bases

Tileable shower bases for every bathroom

**Unlimited possibilities
with hard foam support material**

■ **Models for every installation situation**

in a corner, in a niche or as a replacement for a bath tub

■ **For concrete and timber substrates**

low installation heights and sophisticated drainage technology

■ **With point drainage or floor channel drain**

high drainage capacity and elegant design

■ **Large range of matching accessories**

from the drainage technology to the processing set

■ **Made-to-measure designs are also possible**

e.g. non-standard shapes, sizes and thicknesses

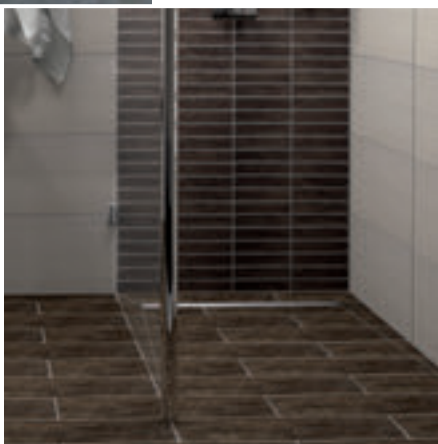

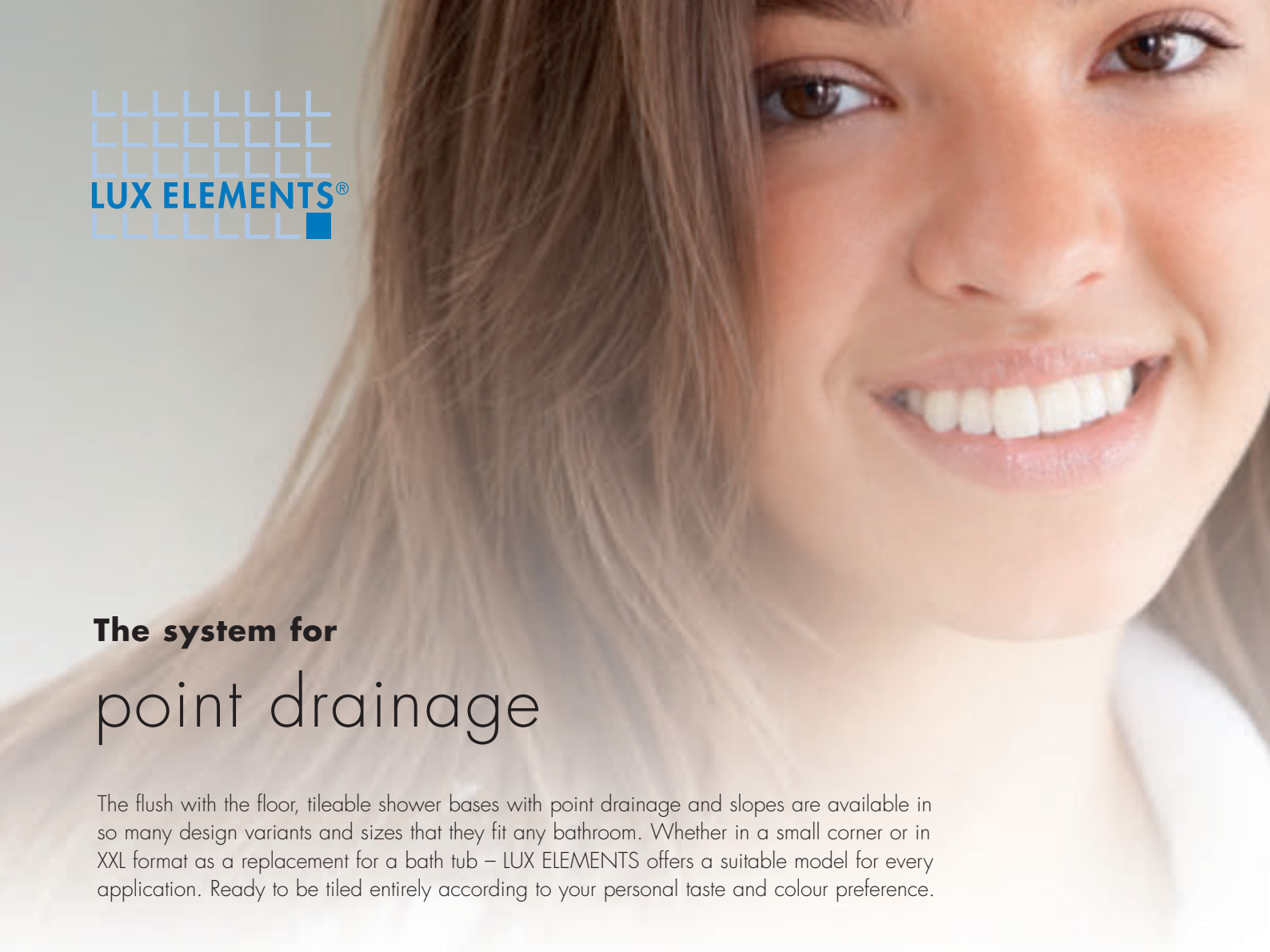

The system for point drainage

The flush with the floor, tileable shower bases with point drainage and slopes are available in so many design variants and sizes that they fit any bathroom. Whether in a small corner or in XXL format as a replacement for a bath tub – LUX ELEMENTS offers a suitable model for every application. Ready to be tiled entirely according to your personal taste and colour preference.

Standard grate

Grate variants see page 18 and 44

Grate fitting frame

Shower base element

Drain connection fitting

vertical or horizontal
firmly connected by click-system
see page 44 and 48

Universal substrate element

optional

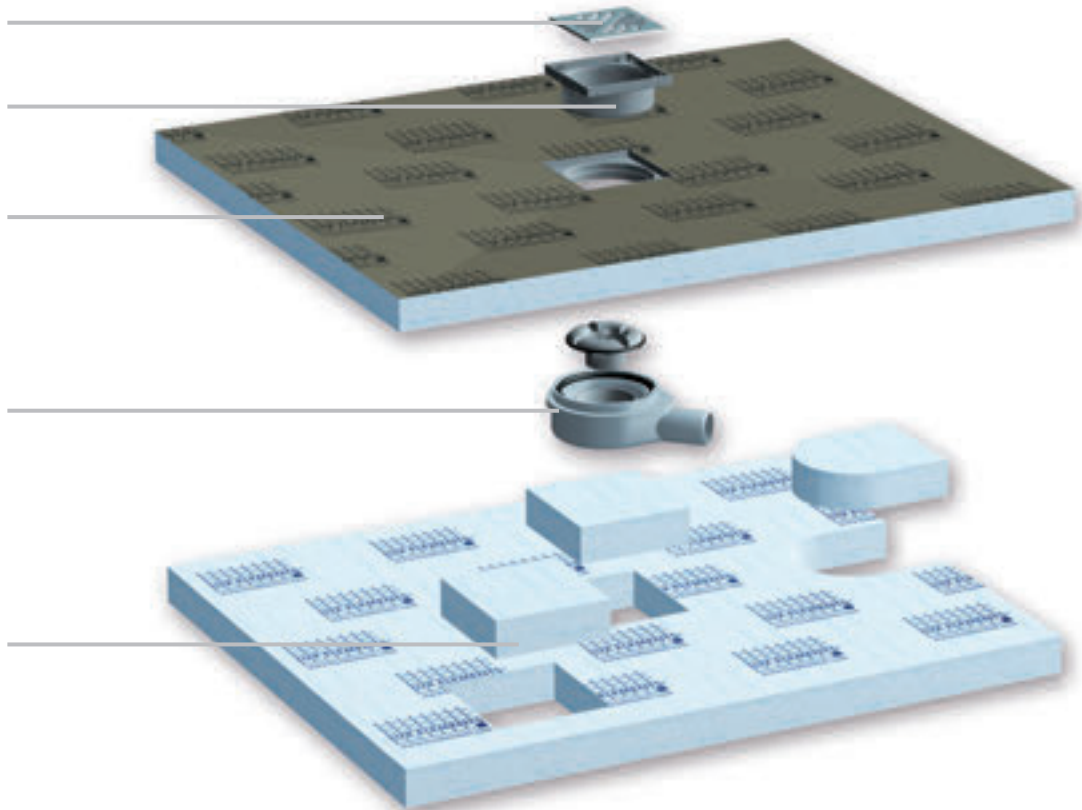

The schematic illustration shows the **TUB-RA-S + TUB-MR + TUB-BA-W + universal substrate element TUB-UR**

LUX ELEMENTS – The Experience

Shower bases

The system for linear drainage

The TUB-LINE models are exactly the right product for those who like linear drainage. In these flush with the floor shower bases, the floor channel drain is already integrated and sealed in. The cover rail is made of brushed stainless steel. The sophisticated height adjustment technology make nearly every ceramic covering possible, from mosaic to natural stone – and hence a particularly large amount of freedom for individual design.

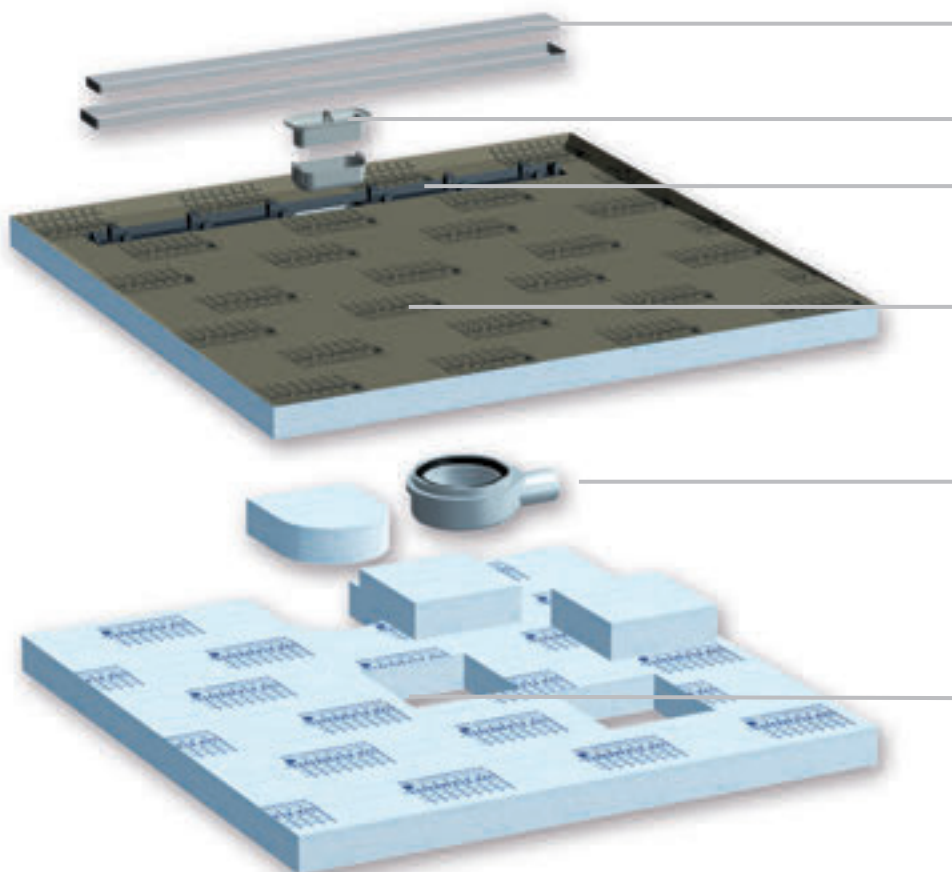

Cover rail

reversible, see page 19, with tiling aid

Odour trap

sealed-in drain channel

with adapters that can be cut as required, see page 57

Shower base element

with 1- or 4-sided gradient

Drain connection fitting

vertical or horizontal
firmly connected by click-system
see page 48

Universal substrate element

optional

The schematic illustration shows the
TUB-LINE Q4 900 + TUB-LINE BA-W + universal substrate element TUB-UQ

Overview TUB

LUX ELEMENTS®-TUB – point drainage



TUB –
flush with the floor shower bases

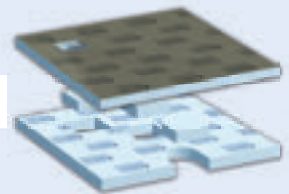

TUB-MQ-SET 300 –
shower drain element

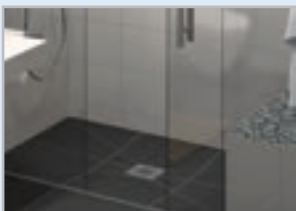

TUB BOL –
flush with the floor shower bases
for the substitution of bath tubs

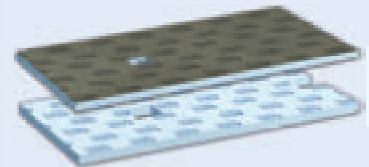

TUB H –
flush with the floor shower bases
for the use on wooden sub-constructions



TUB COMBI –
extra-slim shower bases
with integrated drain technology



TUB floor drain systems and accessories



LUX ELEMENTS®-TUB – further areas of application



TUB-PL –
for alternative
water-resistant
coverings



TUB-PUMP –
with integrated
floor drain pump

LUX ELEMENTS – The Experience

Shower bases

LUX ELEMENTS®-TUB-LINE – linear drainage



TUB-LINE –
flush with the floor shower bases

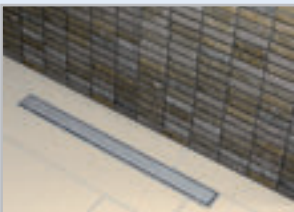
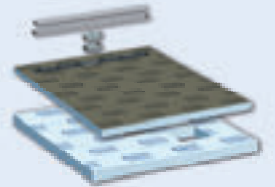

TUB-LINE RT –
channel support elements

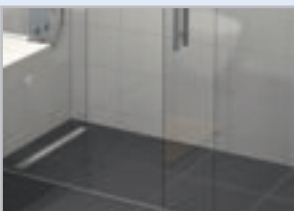
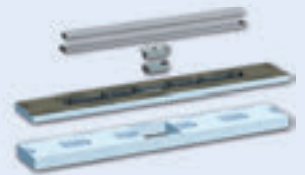

TUB-LINE BOL –
flush with the floor shower bases
for the substitution of bath tubs

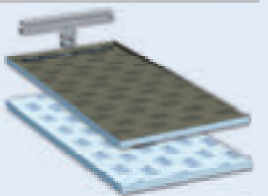

TUB-LINE H –
flush with the floor shower bases
for the use on wooden sub-constructions

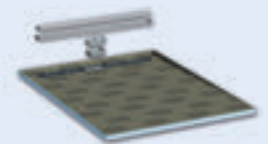

TUB-LINE COMBI –
extra-slim shower bases
and channel support elements
with integrated drain technology

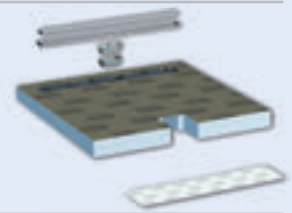

TUB-LINE floor drain systems and accessories



TUB-WALL –
with integrated wall drain





Special designs for special requirements

Standard products – variety of design and many sizes

Point drainage

The TUB shower base is available as a standard product in the design variants square, rectangle, pentagon and quadrant with different drain positions and in many sizes. LUX ELEMENTS thus offers a particularly large choice!

Linear drainage

Flush with the floor hard foam shower base elements for TUB-LINE linear drainage are available as a standard product in square or rectangular versions with integrated and sealed floor channel drain (70 x 750 mm or 70 x 850 mm).

For all shower bases there are matching substrate elements. Universal substrate elements, square or rectangular, in various sizes, are offered for the standard sizes. They fit several standard shower bases respectively with point and linear drainage.



LUX ELEMENTS – The Experience

Shower bases

Custom made – easy and uncomplicated



We also produce made-to-measure and customised products on request. Sizes, shapes, thicknesses etc., that do not correspond to the standard range can be enquired about separately at LUX ELEMENTS. After successful verification of the feasibility we will create a non binding offer. Once we receive your order, the order will be manufactured and delivered. These custom-made products carry the name TUB-PLUS.





Point drainage

Sophisticated drain grates for every taste

For a particularly elegant drain design, seven beautiful design grates are available in addition to the standard stainless steel grate, including two grates with a tileable cover. An eye-catcher for any bathroom!



Improved safety due to locking system

Two design grates have a locking system. This protects the grate against unauthorized removal and is particularly recommended for the public and commercial area. A particular advantage is the quick and easy opening and closing of the system by means of the enclosed key. No screws are required and small parts cannot fall into the drain.



LUX ELEMENTS – The Experience Shower bases



cover rail tiled

Linear drainage

Design cover rail

The system offers two design options due to a reversible channel cover rail. One side has a brushed stainless steel surface, the other can be tiled to match the entire shower base, so that the channel can adapt the tile pattern of the remaining surface. By simply turning, the desired side faces upwards. The cover rail and a loose frame as a tiling aid are made of brushed stainless steel.



cover rail turned, brushed stainless steel





Individual design

Your choice of tiles

Tiles make every bathroom unique, entirely according to personal taste. In addition to various shapes and materials such as ceramic, glass or natural stone, there is an endless choice of colours, patterns and possible combinations. The tile cut also contributes to the design, in particular with flush with the floor shower bases.

Tile design with point drainage

If the shower base has point drainage and the design makes use of large tile formats, the tile cut is already influenced by the position of the drain (central, corner or off-centre) and the existing slope. Alternatively it is possible to design the surface of the shower base with a round or angular mosaic (see page 57).



LUX ELEMENTS – The Experience

Shower bases

Slope variants, linear drainage

Two slope variants are offered for the TUB-LINE shower base models with integrated floor channel drain: the 4-sided slope runs from the outer edges to the channel. In the case of the single-sided slope, there is only one slope direction – from the front edge of the shower base to the floor channel drain.

This kind of slope has a visible effect on the layout of the tile covering. Personal taste, the installation situation and the tile design can decide which variant is selected. With both options the water flows reliably down to the channel.



NOTE:

Technical details and accessories from page 48 onward.

For further information, please refer to our documents. Data sheets, test certificates and processing instructions can be downloaded from www.luxelements.com

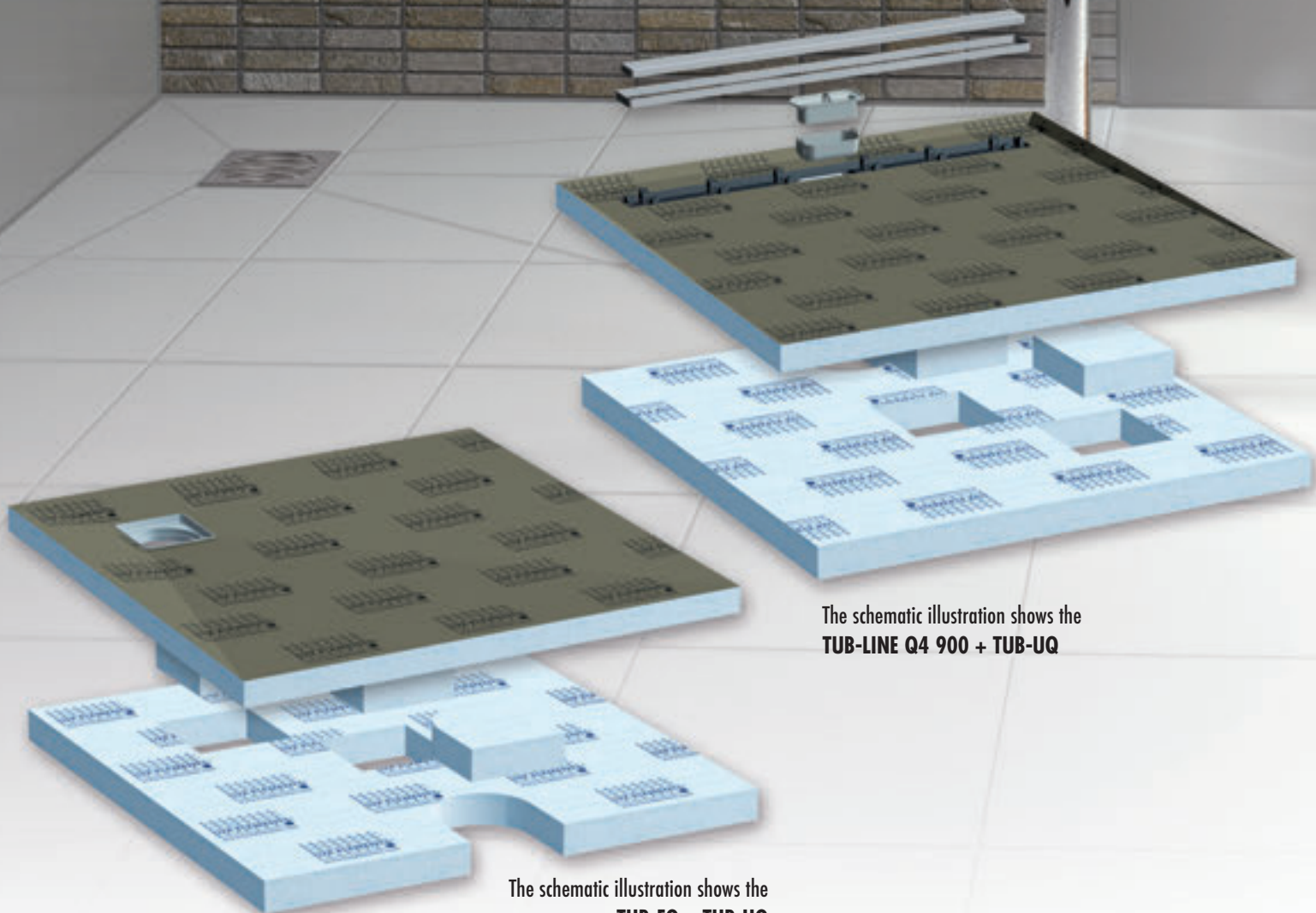

The schematic illustration shows the **TUB-LINE Q4 900 + TUB-UQ**

The schematic illustration shows the **TUB-EQ + TUB-UQ**

LUX ELEMENTS – The Experience

Shower bases

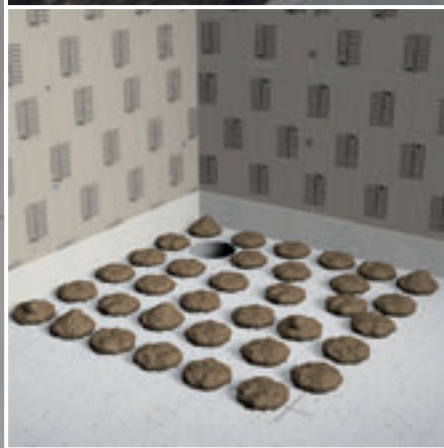
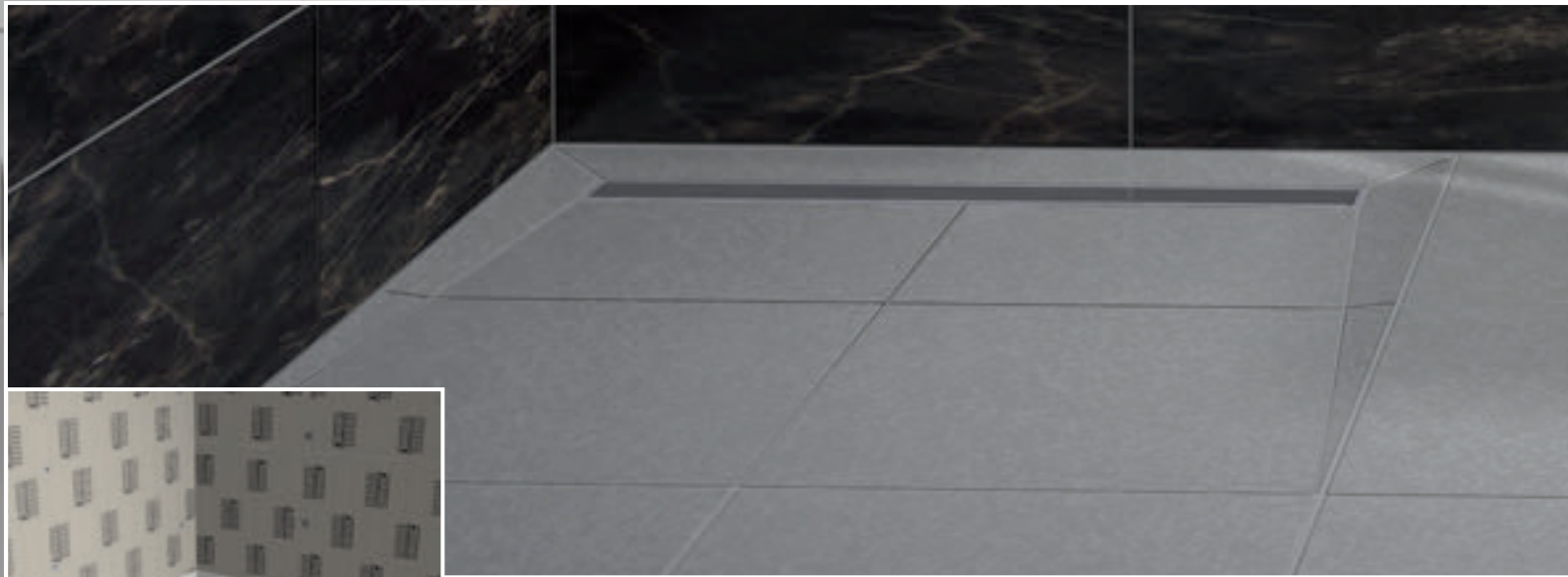

Point and linear drainage

Shower bases for universal employment

LUX ELEMENTS offers shower bases for every bathroom – whether it be in the generous space of an old building or in the nooks and crannies of the attic. Both for renovation and for the construction in new buildings. With its optimally coordinated components, the TUB system is the result of many years of experience and constant further development.

For example, the flush with the floor shower bases are perfect for installation on mineral-based substrates such as concrete or screed. A special fixing adhesive helps to compensate for unevenness in the floor and a substrate element facilitates the installation of the pipework. Everything from one source – for the safe and fast arrangement of the shower area.

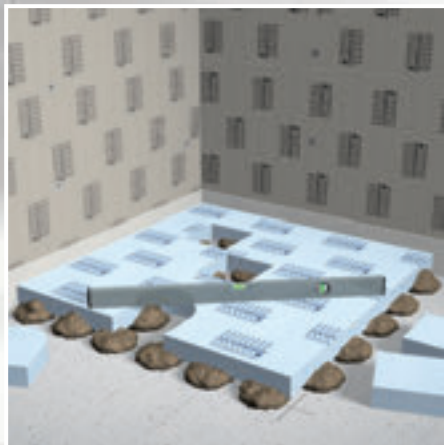

Universal substrate elements for standard sizes

Universal substrate elements, square or rectangular, in various sizes, are offered for the standard sizes of point and linear drainage.

The cutouts for the central, decentralized and linear drain have already been made. Depending on the drain position, the opening that is not required is closed using an enclosed filler.

NOTE:

Technical details and accessories from page 48 onward.

For further information, please refer to our documents. Data sheets, test certificates and processing instructions can be downloaded from www.luxelements.com

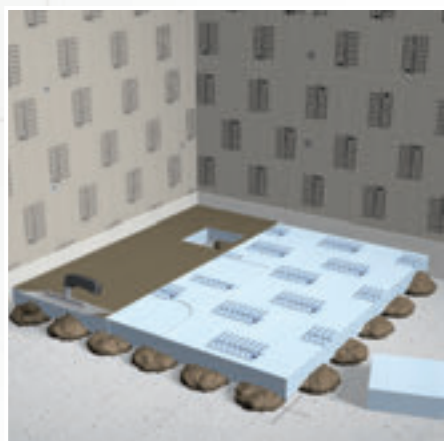

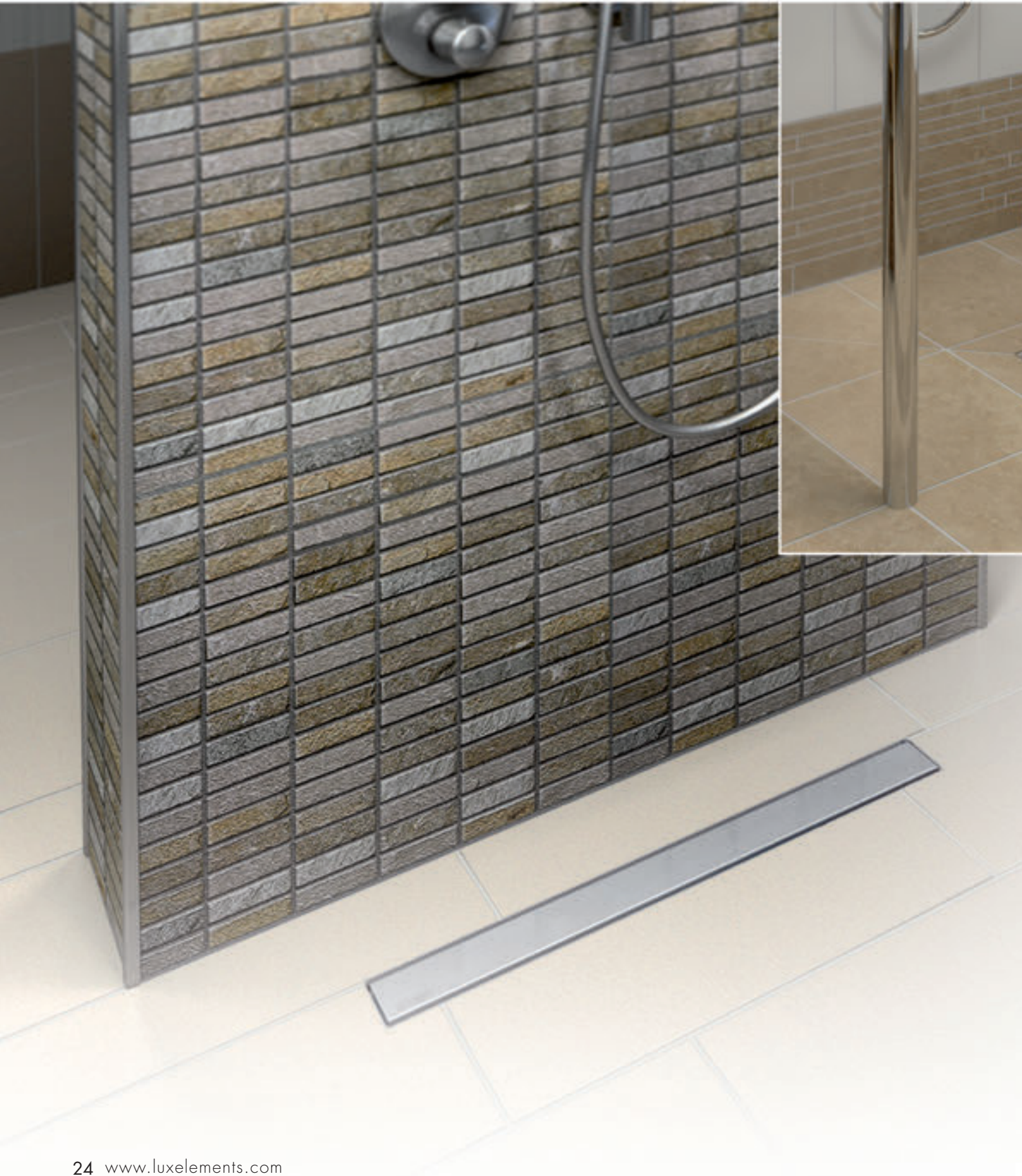

LUX ELEMENTS – The Experience

Shower bases

The flexible variant

If a screed floor with a slope already exists, then a shower drain element or a channel support element is the ideal solution for the secure installation of a shower.



The schematic illustration shows the **TUB-MQ-SET 300**

Point drainage

The TUB-MQ-SET 300 hard-foam shower drain element with built-in 135 x 135 mm floor drain fitting frame, loose sealing sleeve and substrate element is suitable for creating a point drainage.

Linear drainage

If linear drainage is desired, then the TUB-LINE RT, the channel support element with integrated channel drain (650 mm, 750 mm or 850 mm long) and a width of just 20 cm, is a suitable product for the secure mounting of the drain technology. (see also TUB-LINE, page 13)

Matching gradient elements for all channel supports

There are matching gradient elements made of hard foam support material for even more possible uses of the channel support elements. These can be applied at one or at both sides of the support element. If necessary the gradient elements can be shortened at the higher side, for example in order to adapt them to a niche.

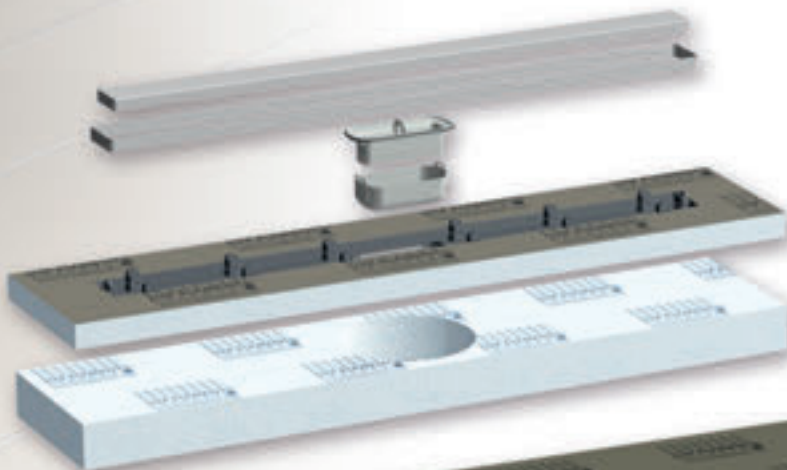

The schematic illustration shows the **TUB-LINE RT 900/200 (750)**

Combination possibilities

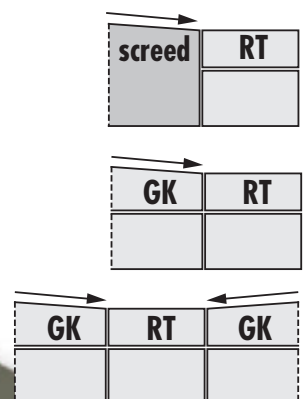

The schematic illustration shows the **TUB-LINE GK R1 1200/900**
+ **TUB-UR 1200/900**

LUX ELEMENTS – The Experience

Shower bases

before



after

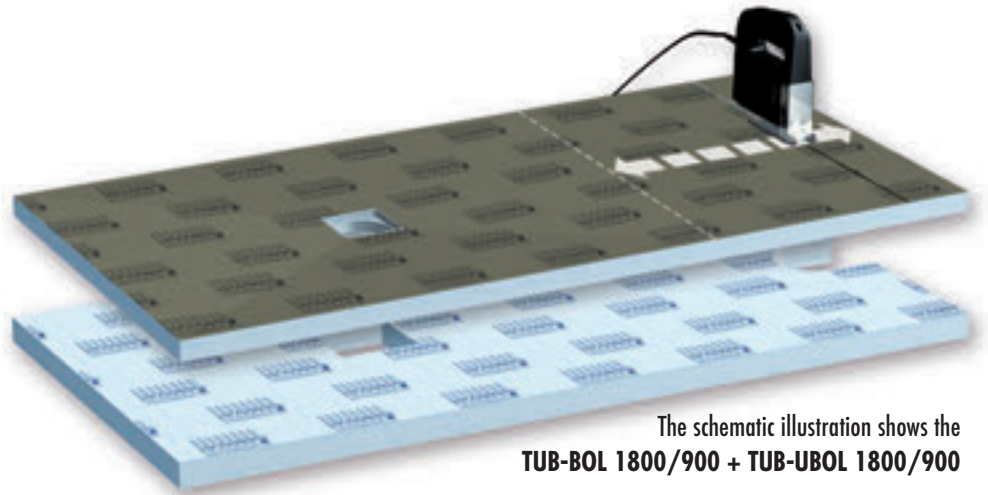

The schematic illustration shows the **TUB-BOL 1800/900 + TUB-UBOL 1800/900**

Universal substrate element

There is an optional universal substrate element, TUB-UBOL, which is suitable for point and linear drainage.

Accessories for point and linear drainage

Optionally you can also supplement the shower base with partition walls and/or seats made of hard foam support material. You can choose between a range of standard products or individual custom designs. Suitable seatings, for example, are the RELAX-BA-SOLO-G and CONCEPT-BA-STAR benches. RELAX-BA-SOLO-G already exist as a standard product available in the widths of the BOL shower trays.

The extra-slim product TUB-COMB BOL is suitable for older buildings with particularly low installation heights (see page 32).



The schematic illustration shows the **RELAX-BA-SOLO-G + CONCEPT-BA-STAR**

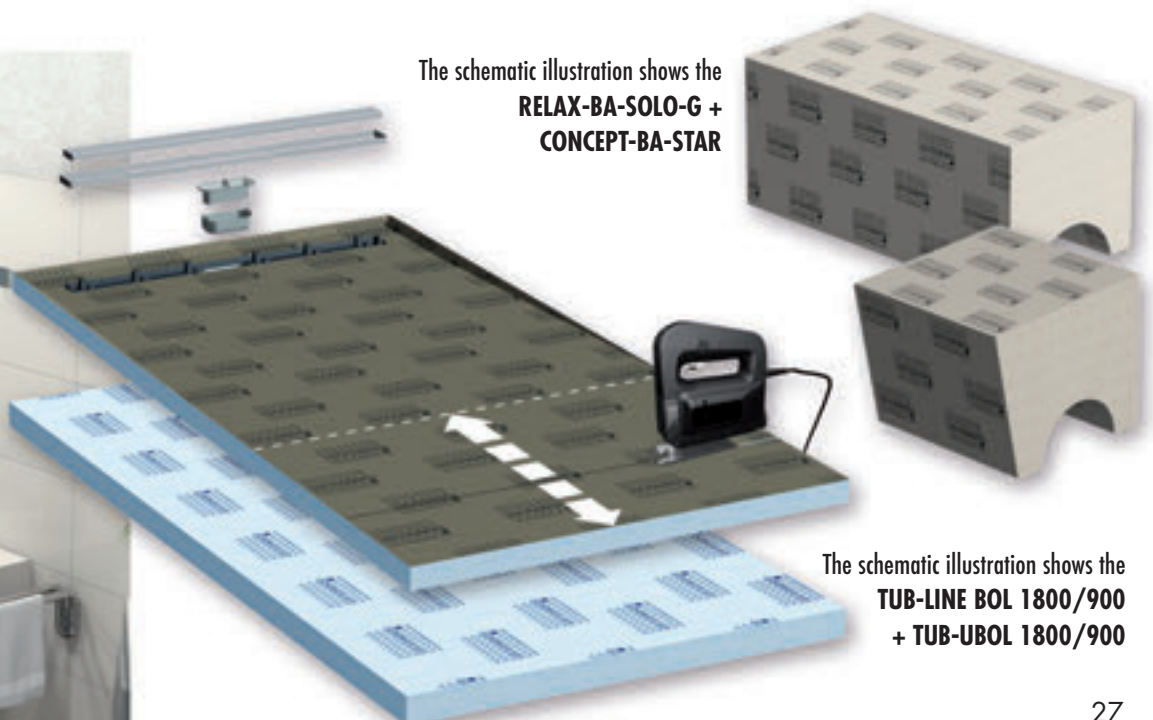

The schematic illustration shows the **TUB-LINE BOL 1800/900 + TUB-UBOL 1800/900**

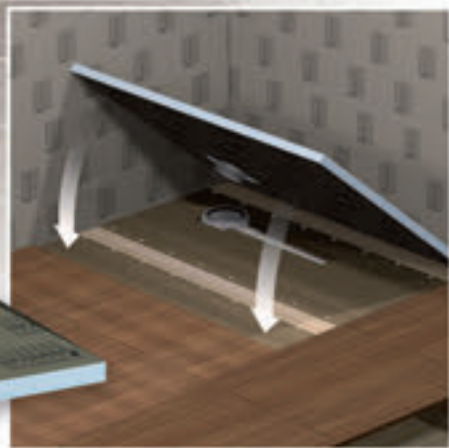
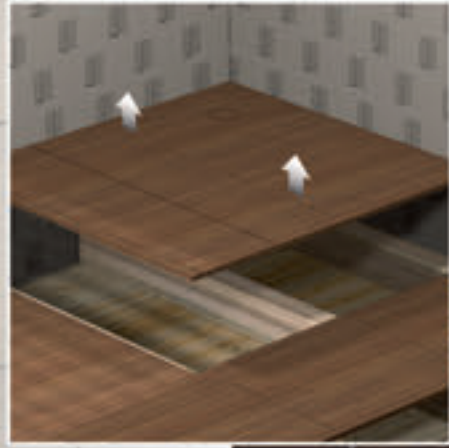

LUX ELEMENTS – The Experience

Shower bases

Shower bases for the use on wooden sub-constructions

One does not always find concrete floors in buildings. Due to national building methods, in the case of wooden buildings or old buildings, a supporting timber construction with wooden floorboards may form the substrate for a shower base. This calls for particularly flat products.

Point drainage

The TUB-HEQ/HER and TUB-HMQ/HMR shower base models by LUX ELEMENTS meet this requirement with an installation height of 15/30 mm and a built in slope, so that they can be integrated optimally into existing wooden floors. A special reinforcement on the underside provides for high stability.

Linear drainage

The TUB-LINE H... models (square and rectangular) are suitable for drainage with a channel drain on wooden floors. With an installation height of 20/30 mm and an integrated 4-sided slope, these shower bases are particularly flat. Both models are equipped with a reversible stainless steel channel cover (see page 19).

Shower bases for bath tub replacement

LUX ELEMENTS offers a hard-foam shower base model for both point and linear drainage for bath tub replacement on wooden sub-constructions. TUB-H BOL 1800/900 and TUB-LINE H BOL 1800/900 can be shortened to any length down to 1200 mm by division into an area with a slope and an area without a slope (see page 27).



The schematic illustration shows the
TUB-HER 1400/900

NOTE:

Technical details and accessories from page 48 onward.

For further information, please refer to our documents. Data sheets, test certificates and processing instructions can be downloaded from www.luxelements.com

LUX ELEMENTS – The Experience

Shower bases



Point drainage

The TUB-COMBI models combine a shower base or shower drain elements with a horizontal floor drain, which is already integrated. The substrate element is therefore omitted and the showerbase with its **68 mm** construction height at the drain is **particularly flat**. In addition, the TUB-COMBI shower bases in conjunction with the horizontal floor drain support DN 50 have a very high drainage capacity of 60 l/min.

Linear drainage

In the TUB-LINE COMBI hard foam shower base elements or channel support elements a high quality channel drain is installed and sealed. This has a reversible stainless steel channel cover. (see page 19). In addition, a horizontal floor drain DN 50 is already integrated.

The shower bases are at **68 mm particularly flat** at the lowest point of the slope and rise to only 80 mm at the outer edge. Due to the integration of the horizontal drain system, additional height for installation is not required. A plastic reinforcement on the top side provides the necessary stability. This means that, even in older buildings, there is no reason to do without no-threshold shower fun and with adequately highflow rate (31,2 l/min).

All hard foam shower base elements have a slope. Two models are available here. The four-sided slope runs from all four edges to the channel. A one-sided slope is offered as an alternative.

TUB-LINE COMBI

The principle

**Channel cover
with tiling aid**

Shower base element

Floor drain system

Plastic reinforcement

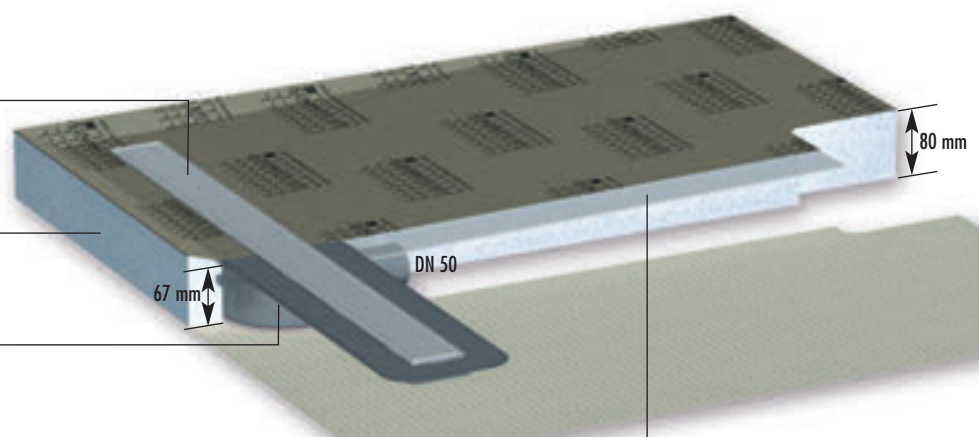

TUB-COMBI

The models

TUB-COMBI MQ 300

Extra-slim hard foam shower drain element incl. loose sealing sleeve. Suitable for the installation of a shower in screed floors with a slope or for subsequent forming of the slope.

TUB-COMBI MQ/ER/MR

Extra-slim hard foam shower base elements, square and rectangular, with drain in the centre or off-centre, for mineral substrates. A separate sealing sleeve, which is enclosed as a loose part, serves for sealing the piping.

TUB-COMBI BOL 1800/900

Extra-slim hard foam shower base element for the replacement of bath tubs, can be cut to size up to min. 900 x 1200 mm (see page 26). A separate sealing sleeve, which is enclosed as a loose part, serves for sealing the piping.

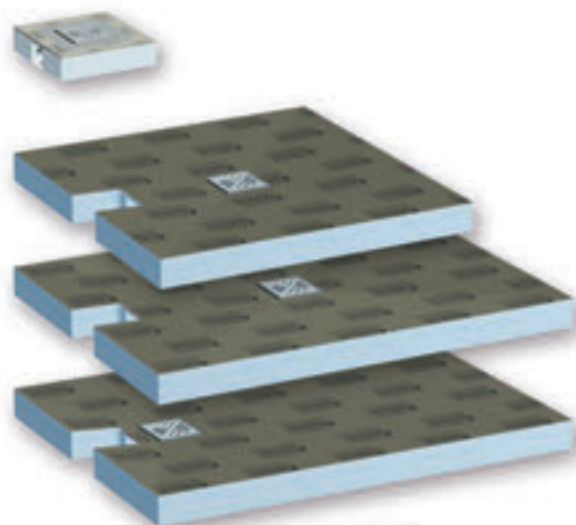

LUX ELEMENTS – The Experience

Shower bases



TUB-LINE COMBI

The models

TUB-LINE COMBI Q1/Q4/R1/R4

Extra-slim square or rectangular shower base elements with floor channel drain (70 x 750 mm), incl. loose sealing sleeve and a single-sided or 4-sided gradient in many formats for conventional installation situations, e.g., in the corner or in front of a wall.

TUB-LINE COMBI RT / AE / GK

Extra-slim hard foam channel support element with sealed floor channel drain (70 x 650 mm, 70 x 750 mm or 70 x 850 mm), equipped with a reversible stainless steel channel cover (see page 19).

The connecting element **TUB-LINE COMBI AE** is reinforced at the surface and is used for the safe covering of the drain pipe. A suitable HTK elbow with swivel joint, which can be adjusted to an angle of 0–87°, is available as an accessory (see page 49). The channel support elements are suitable for the installation of a shower in screed floors with a slope or in combination with hard foam gradient elements **TUB-LINE COMBI GK** (see page 25).

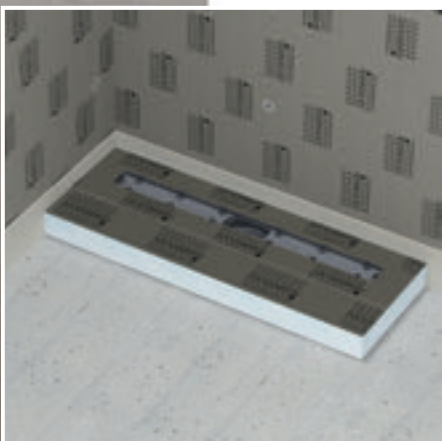
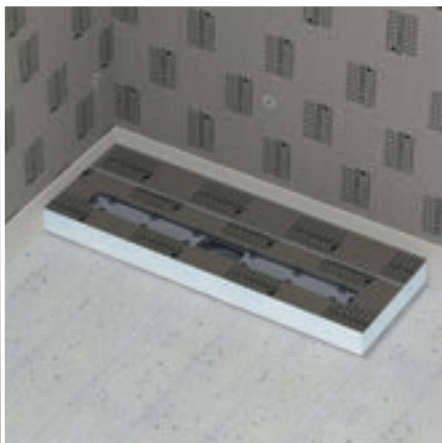
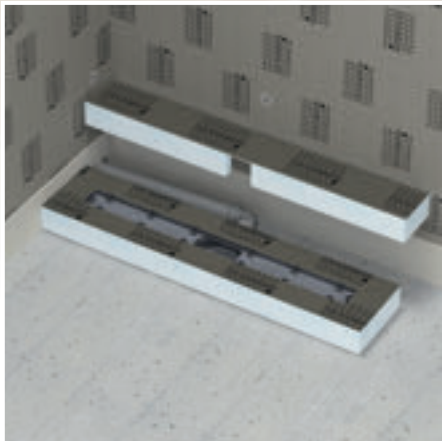

single-sided slope

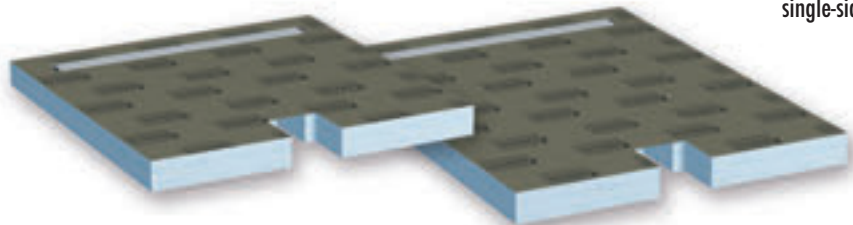

4-sided slope

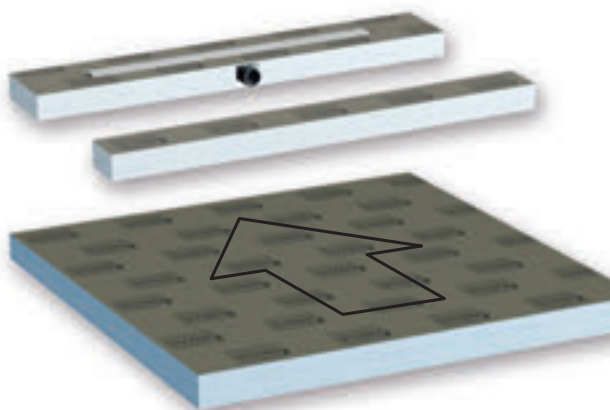
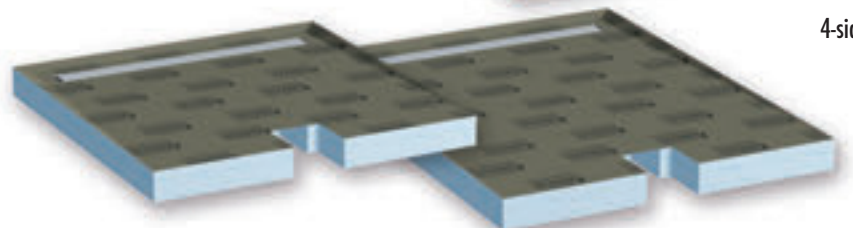

NOTE:

Technical details and accessories from page 48 onward. For further information, please refer to our documents. Data sheets, test certificates and processing instructions can be downloaded from www.luxelements.com



LUX ELEMENTS – The Experience

Shower bases

Further areas of application

Ensures drainage under soft floor coverings

If a shower is installed with such soft floor coverings in a wet area, then a highly resistant shower element is necessary to comply with all the relevant pressure points which are exerted e.g. by wheelchairs or walking aids. The solution for fulfilling these demands is called **TUB-PL**.

TUB-PL is suitable for accommodating alternative, waterproof floor covering. These may not only be web material such as PVC (TUB PL-B) but also coatings (TUB PL-S). The highly pressure-resistant surface of the elements is waterproof and fitted with a slope.

As the shower bases are individually dimensioned, they are perfectly suited for the specific building conditions. The factory production methods in the LUX ELEMENTS works ensure this flexibility.

Appropriate drainage technology

The matching drainage technology consists of a grate fitting frame and grate made as well as a horizontal or vertical floor drain support DN 50 with odour trap. Depending on the type of covering, two variants are offered: one version with a clamping rim for the accommodation of web material and a further model for coated shower bases with coating. Drain performance: TUB PL-B vertical (TUB-PL BAS) + horizontal (TUB-PL BAW): 48 l/min; TUB PL-S vertical (TUB BA-S): 102,6 l/min; TUB PL-S horizontal (TUB BA-W): 60 l/min

If different, building-related drainage technology be required or desired, this can also be combined with the shower bases TUB-PL after checking the technical feasibility.

The schematic illustration shows the
TUB-PL-B + drain system

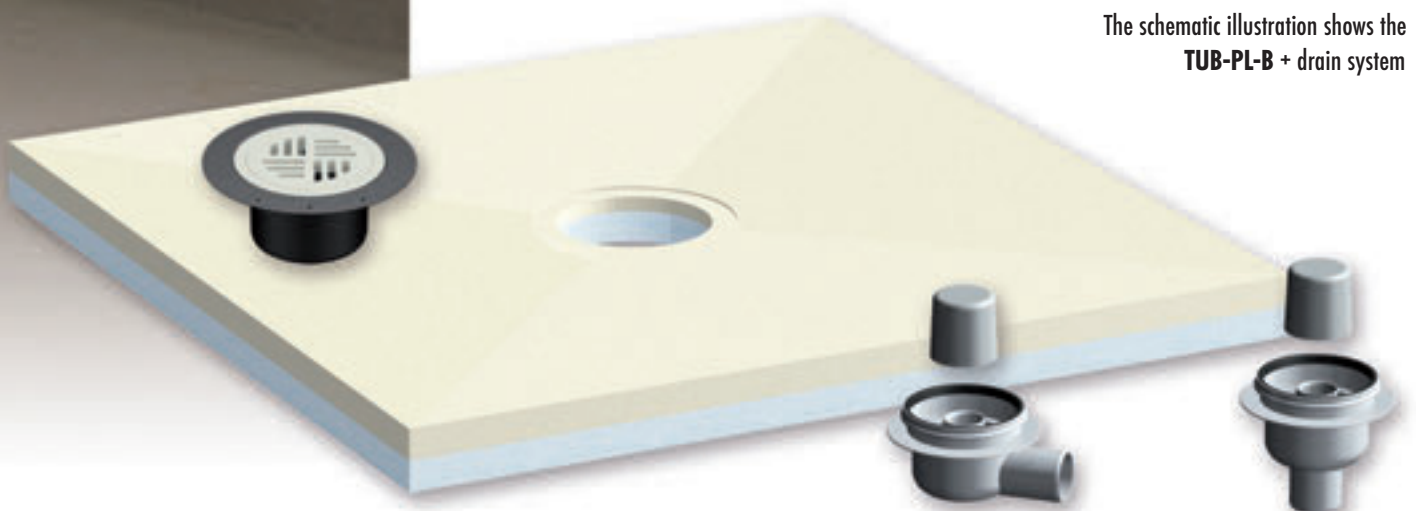



LUX ELEMENTS – The Experience

Shower bases

Further areas of application

The first flush with the floor shower base which pumps itself

It is not always possible to install a flush with the floor shower without any obstructions. The gravitational force does not work wherever the wastewater cannot be drained with sufficient gradient to the downpipe. One of the most common challenges is, for example, replacing an old raised shower base with a modern flush with the floor shower. The connection point to the downpipe in older buildings is often a few centimetres too high.

The perfect solution for such cases is the installation of a shower base with an integrated and sealed-in floor drain pump. The first product on the market, which fulfils these requirements, is **TUB-PUMP** von LUX ELEMENTS (Example for the drainage capacity of the floor drain pump: 35 l/min at 1,35 m height difference).

TUB-PUMP is available as standard in two square and two rectangular sizes. The two associated substrate elements in different heights offer flexibility for adaptation to various installation situations in the floor. The 2-piece stainless steel reversible grate makes several design variants possible. One side has a stainless steel surface; the other can be tiled to match the showerbase. By simply turning, the desired side faces upwards. In addition, the scope of delivery includes a further grate section with a sun-shaped pattern.

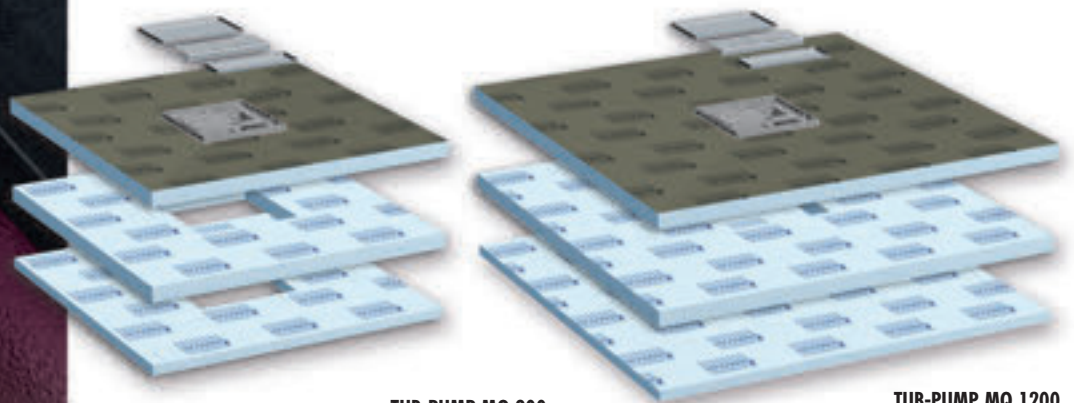

TUB-PUMP MQ 900

TUB-PUMP MQ 1200

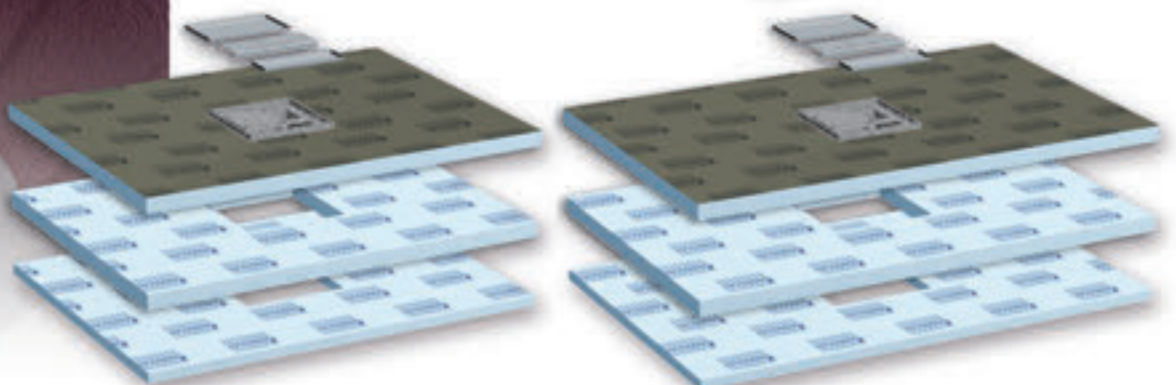

TUB-PUMP MR 1200/900

TUB-PUMP MR 1400/900



LUX ELEMENTS – The Experience

Shower bases

Further areas of application

Shower drain element with integrated wall drain

The TUB-WALL hard foam shower drain elements, in two widths with integrated wall drain, enable a new shower experience with a continuous floor surface finish. The supplied stainless steel cover for the drain (drain performance: 31,2 l/min) can be tiled and integrates itself so well into the wall that it is almost invisible.

In order to enable a wide selection of tiles and ceramics for the surface design, TUB-WALL is available with both a single-sided and a 3-sided gradient.

Installation is easy, fast and clean. The supplied sealing sleeve ensures a reliable sealing around the drain area. A removable odour trap is also available with the product.

Matching gradient elements

Optionally available are matching gradient elements TUB-LINE COMBI GK... for all TUB-WALL shower drain elements. If necessary, they can be cut to size on the higher side. Like the slope variants for the floor drain elements, the gradient elements are also equipped with single-sided and 3-sided gradient.

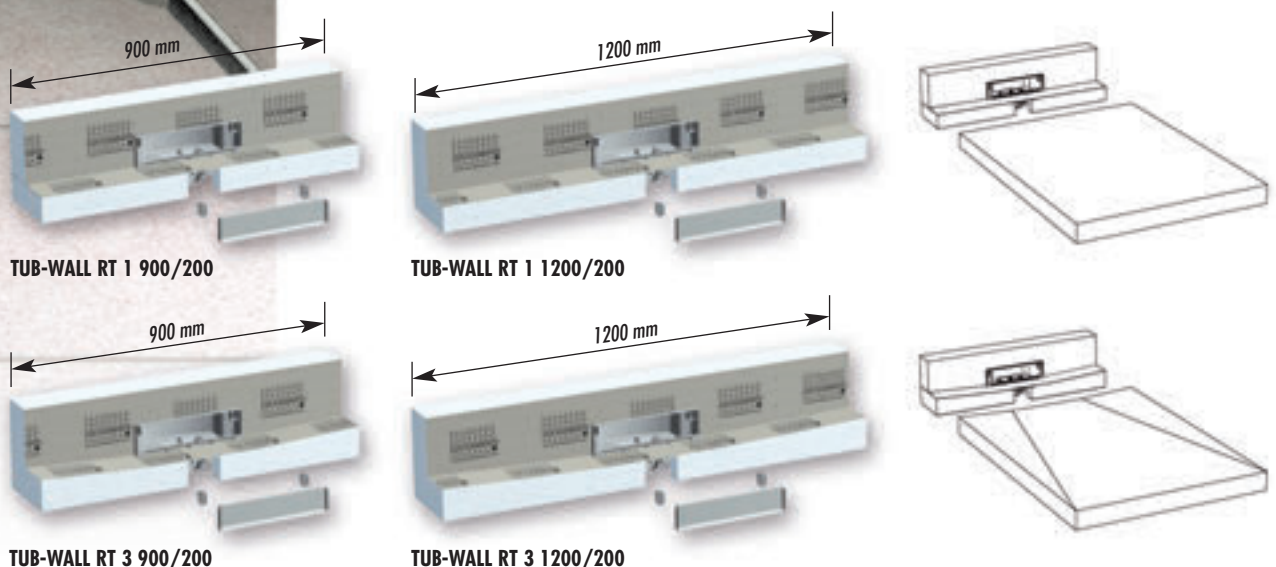

Programme summary

Point drainage

TUB – flush with the floor shower bases

Hard foam shower base elements, four basic shapes, with integrated and sealed floor drain support frame 135 x 135 mm.

Drain position: in the corner or off-centre

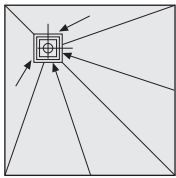

■ **TUB-EQ ...**, square
Standard dimensions up to 1500 x 1500 x 30/45 mm, custom-made elements up to 1600 x 1600 x 30/45 mm. Drain in the corner.

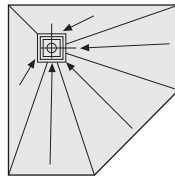

■ **TUB-EF ...**, pentagonal
Standard dimensions up to 1000 x 1000 x 30/45 mm, custom-made elements up to 1200 x 1200 x 30/45 mm. Drain in the corner.

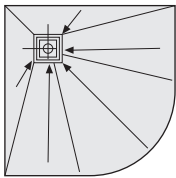

■ **TUB-EK ...**, quadrant
Standard dimensions up to 1000 x 1000 x 30/45 mm, custom-made elements up to 1200 x 1200 x 30/45 mm. Drain in the corner.

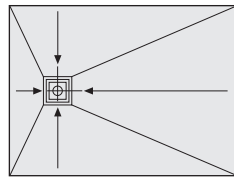

■ **TUB-ER ...**, rectangular
Standard dimensions up to 1600 x 900 x 30/45 mm, custom-made elements up to max. side length 2200 mm. Drain off-centre.

Drain position: in the centre

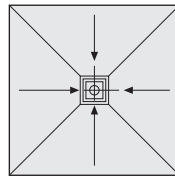

■ **TUB-MQ ...**, square
Standard dimensions up to 1500 x 1500 x 30/45 mm, custom-made elements up to 1600 x 1600 x 30/45 mm. Drain in the centre.

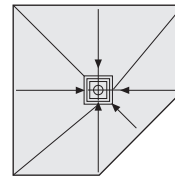

■ **TUB-MF ...**, pentagonal
Standard dimensions up to 1000 x 1000 x 30/45 mm, custom-made elements up to 1200 x 1200 x 30/45 mm. Drain in the centre.

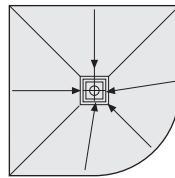

■ **TUB-MK ...**, quadrant
Standard dimensions up to 1000 x 1000 x 30/45 mm, custom-made elements up to 1200 x 1200 x 30/45 mm. Drain in the centre.

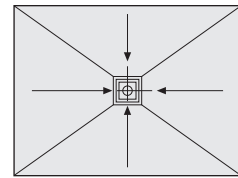

■ **TUB-MR ...**, rectangular
Standard dimensions up to 1600 x 900 x 30/45 mm, custom-made elements up to max. side length 2200 mm. Drain in the centre.

Special formats – TUB-PLUS

You can not find the right product? We also manufacture made-to-measure! Sizes, shapes, thicknesses etc., that do not correspond to the standard range can be enquired about separately at LUX ELEMENTS. After successful verification of the feasibility we will create a non binding offer. Once we receive your order, the order will be manufactured.



TUB-MQ-SET 300 – shower drain element

Hard foam shower drain 300 x 300 x 30 mm element with integrated floor drain support frame 135 x 135 mm, loose sealing sleeve 400 x 400 mm and substrate element TUB-UMQ 300 x 300 x 55 mm.



■ **TUB-MQ-SET 300**

TUB-BOL – flush with the floor shower bases as a substitute for bath tubs

Hard foam shower base elements, rectangular, with integrated and sealed floor drain support frame 135 x 135 mm.

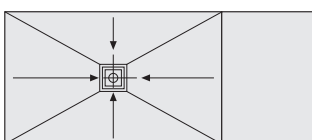

■ **TUB-BOL 1800/750**
rectangular, 750 x 1800 x 30/45 mm, can be cut to length to minimum 750 x 1200 mm, slope area from 750 x 1200 mm, drain in the slope area in the centre.

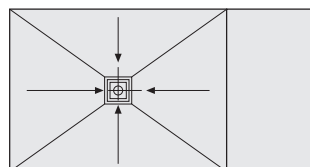

■ **TUB-BOL 1800/900**
rectangular, 900 x 1800 x 30/45 mm, can be cut to length to minimum 900 x 1200 mm, slope area from 900 x 1200 mm. Drain in the slope area in the centre.

LUX ELEMENTS – The Experience

Shower bases

Linear drainage

TUB-LINE – flush with the floor shower bases

Hard foam shower base elements, square or rectangular, with 1- or 4-sided slope, with integrated and sealed floor channel drain on shorter side. Cover rail brushed stainless steel or tileable on rear side, with odour trap, height adjustable with height adapter from 5 – 17 mm.

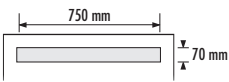

**Floor channel drain:
70 x 750 mm**

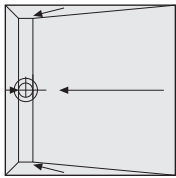

■ **TUB-LINE Q4 ...**, square with **4-sided** slope, standard dimensions 900 x 900 x 30/45 mm. Custom-made elements up to 1000 x 1000 x 30/45 mm.

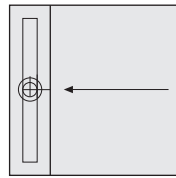

■ **TUB-LINE Q1 ...**, square with **1-sided** slope, standard dimensions 900 x 900 x 30/45 mm. Custom-made elements up to 1000 x 1000 x 30/45 mm.

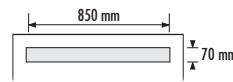

**Floor channel drain:
70 x 850 mm**

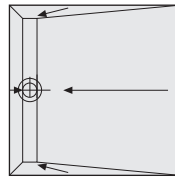

■ **TUB-LINE Q4 ...**, square with **4-sided** slope, standard dimensions up to 1200 x 1200 x 30/45 mm. Custom-made elements up to 1200 x 1200 x 30/45 mm.

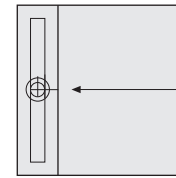

■ **TUB-LINE Q1 ...**, square with **1-sided** slope, standard dimensions up to 1200 x 1200 x 30/45 mm. Custom-made elements up to 1200 x 1200 x 30/45 mm.

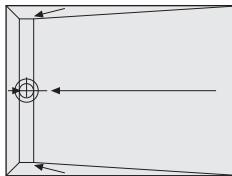

■ **TUB-LINE R4 ...**, rectangular with **4-sided** slope, standard dimensions up to 1600 x 900 x 30/45 mm. Custom-made elements up to max. side length 1600 mm.

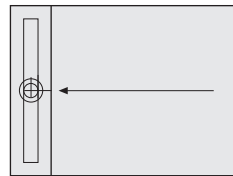

■ **TUB-LINE R1 ...**, rectangular with **1-sided** slope, standard dimensions up to 1600 x 900 x 30/45 mm. Custom-made elements up to max. side length 1600 mm.

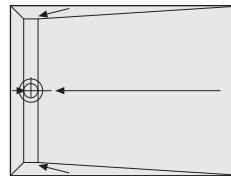

■ **TUB-LINE R4 ...**, rectangular with **4-sided** slope, standard dimensions 1200 x 1000 x 30/45 mm. Custom-made elements up to max. side length 1200 mm.

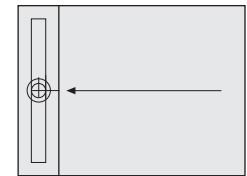

■ **TUB-LINE R1 ...**, rectangular with **1-sided** slope, standard dimensions 1200 x 1000 x 30/45 mm. Custom-made elements up to max. side length 1200 mm.

TUB-LINE RT/GK – channel support and gradient elements

Hard foam channel support element, with sealed floor channel drain in three lengths, cover rail brushed stainless steel or tileable on rear side with odour trap, height adjustable with height adaptor from 5-17 mm. Including a 55 mm high substrate element.



■ **TUB-LINE RT 900/200 (650)** with floor channel drain 70 x 650 mm, standard dimensions 200 x 900 x 30 mm.



■ **TUB-LINE RT 900/200 (750)** with floor channel drain 70 x 750 mm, standard dimensions 200 x 900 x 30 mm.



■ **TUB-LINE RT 1200/200 (850)** with floor channel drain 70 x 850 mm, standard dimensions 200 x 1200 x 30 mm.

Hard foam gradient elements with 1-sided slope, square or rectangular. Substrate element (55 mm high) optional.



■ **TUB-LINE GK R1 1200/900** rectangular, sealed, standard dimensions 1200 x 900 x 30/45 mm.

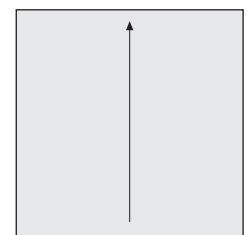

■ **TUB-LINE GK Q1 1200** square, sealed, standard dimensions 1200 x 1200 x 30/45 mm.

TUB-LINE BOL – flush with the floor shower bases as a substitute for bath tubs

Hard foam shower base elements, with 4-sided slope, with integrated and sealed floor channel drain 70 x 750 mm on shorter side. Cover rail brushed stainless steel or tileable on rear side, with odour trap, height adjustable with height adapter from 5 – 17 mm.

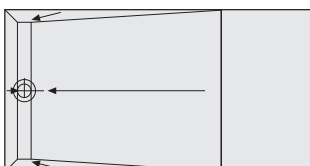

■ **TUB-LINE BOL 1800/900** rectangular, 1800 x 900 x 30/45 mm, can be cut to length to minimum 900 x 1200 mm, slope area from 900 x 1200 mm.

Universal substrate elements

Universal substrate elements in various sizes are offered for the standard sizes. They fit several standard shower bases respectively; for the customised shower bases the substrate elements including the drain position are also made to measure.

Programme summary

Point drainage

TUB-H – flush with the floor shower bases on wooden sub-constructions

Hard foam shower base elements, square or rectangular, with integrated and sealed-in floor drain fitting frame 135 x 135 mm.

Drain position: in the corner

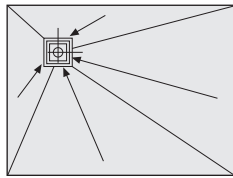
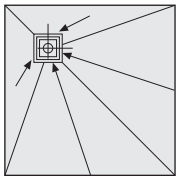

■ **TUB-HEQ ...**
square, standard dimensions up to 1200 x 1200 x 15/30 mm. Drain in the corner.

■ **TUB-HER ...**
rectangular, standard dimensions up to 1600 x 900 x 15/30 mm. Drain in the corner.

Drain position: in the centre

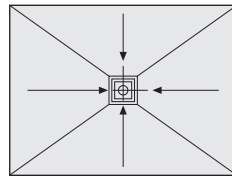
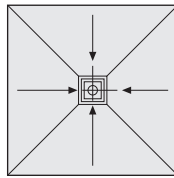

■ **TUB-HMQ ...**
square, standard dimensions up to 1200 x 1200 x 15/30 mm. Drain in the centre.

■ **TUB-HMR ...**
rectangular, standard dimensions up to 1600 x 900 x 15/30 mm. Drain in the centre.

... as a substitute for bath tubs

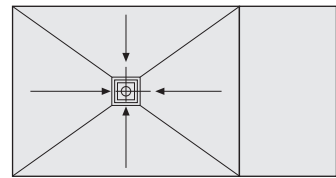

■ **TUB-H BOL 1800/900**
rectangular, standard dimensions 900 x 1800 x 15/30 mm, can be cut to length to minimum 900 x 1200 mm, slope area from 900 x 1200 mm. Drain in the slope area in the centre.

TUB-COMBI – flush with the floor shower bases, integrated drain system

Extra-slim hard foam shower base element with integrated and sealed (not for TUB-COMBI MQ 300) horizontal floor drain incl. grate fitting frame made of ABS and standard stainless steel grate, universal height adjustment to suit tile thickness and sleeve.

Drain position: off-centre

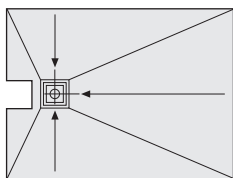

■ **TUB-COMBI ER ...**
rectangular, standard dimensions up to 1400 x 1000 x 68/80 mm, loose sealing sleeve 200 x 800 mm, drain off-centre.

Drain position: in the centre

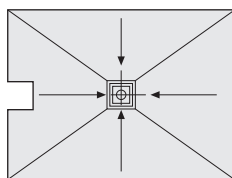
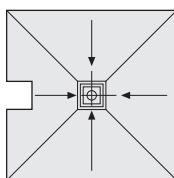

■ **TUB-COMBI MQ 300**
square, standard dimensions 300 x 300 x 68 mm, loose sealing sleeve 400 x 400 mm, drain in the centre.

■ **TUB-COMBI MQ 900**
square, standard dimensions 900 x 900 x 68/80 mm, loose sealing sleeve 200 x 800 mm, drain in the centre.

■ **TUB-COMBI MR 1200/900**
rectangular, standard dimensions 1200 x 900 x 68/80 mm, loose sealing sleeve 200 x 800 mm, drain in the centre.

... as a substitute for bath tubs

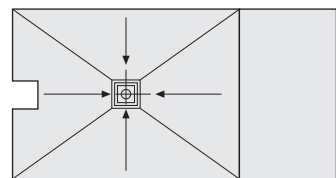

■ **TUB-COMBI BOL 1800/900**
rectangular, standard dimensions 900 x 1800 x 68/80 mm, can be cut to length to minimum 900 x 1200 mm, slope area from 900 x 1200 mm, loose sealing sleeve 200 x 800, drain in the slope area in the centre.

NOTE:

Technical details and accessories from page 48 onward.

For further information, please refer to our documents. Data sheets, test certificates and processing instructions can be downloaded from www.luxelements.com



Installation video on www.m.luxelements.com or visit our new YouTube-Channel on www.youtube.com/user/luxelementscom

Special formats – TUB-PLUS

You can not find the right product? We also manufacture made-to-measure! Sizes, shapes, thicknesses etc., that do not correspond to the standard range can be enquired

about separately at LUX ELEMENTS. After successful verification of the feasibility we will create a non binding offer.

Once we receive your order, the order will be manufactured.



LUX ELEMENTS – The Experience

Shower bases

Linear drainage

TUB-LINE H – flush with the floor shower bases on wooden sub-constructions

Hard foam shower base elements, square or rectangular, 4-sided slope, with integrated and sealed floor channel drain on shorter side. Cover rail brushed stainless steel or tileable on rear side, with odour trap, height adjustable with height adaptor from 5 – 17 mm.

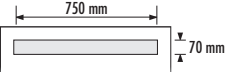
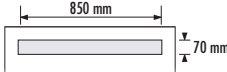
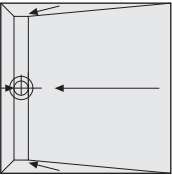
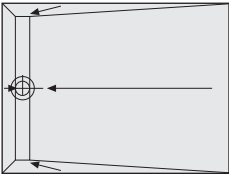
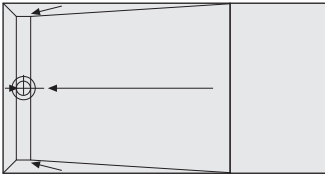
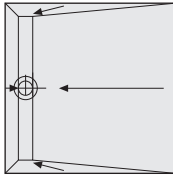
 <p>Floor channel drain: 70 x 750 mm</p>	<p>... as a substitute for bath tubs</p>	 <p>Floor channel drain: 70 x 850 mm</p>
 <p>■ TUB-LINE HQ4 900 square, standard dimensions 900 x 900 x 20/30 mm.</p>	 <p>■ TUB-LINE HR4... rectangular, standard dimensions up to 1400 x 900 x 20/30 mm.</p>	 <p>■ TUB-LINE H BOL 1800/900 rectangular, standard dimensions 1800 x 900 x 20/30 mm, can be cut to length to minimum 900 x 1200 mm, slope area from 900 x 1200 mm.</p>
		 <p>■ TUB-LINE HQ4 ... square, standard dimensions up to 1200 x 1200 x 20/30 mm.</p>

TUB-LINE COMBI – flush with the floor shower bases, integrated drain system

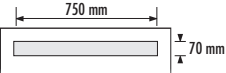
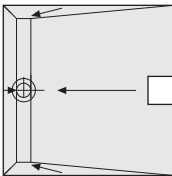
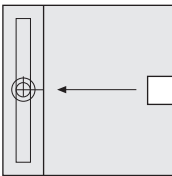
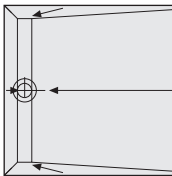
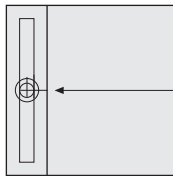

Extra-slim hard foam shower base elements, square or rectangular, with 1- or 4-sided slope, with integrated and sealed floor channel drain on shorter side, including integrated horizontal drain connection fitting, with cover rail and tiling aid made of brushed stainless steel, cover rail tileable on the rear side, with odour trap, height adjustable with height adaptor from 5–17 mm.

 <p>Floor channel drain: 70 x 750 mm</p>			
 <p>■ TUB-LINE COMBI Q4 900 square, with 4-sided slope, standard dimensions 900 x 900 x 67/80 mm, including loose sealing sleeve 200 x 800 mm.</p>	 <p>■ TUB-LINE COMBI Q1 900 square, with 1-sided slope, standard dimensions 900 x 900 x 67/80 mm, including loose sealing sleeve 200 x 800 mm.</p>	 <p>■ TUB-LINE COMBI R4 1200/900 rectangular, with 4-sided slope, standard dimensions 1200 x 900 x 67/80 mm, including loose sealing sleeve 200 x 80 mm.</p>	 <p>■ TUB-LINE COMBI R1 1200/900 rectangular, with 1-sided slope, standard dimensions 1200 x 900 x 67/80 mm, including loose sealing sleeve 200 x 800 mm.</p>

TUB-LINE COMBI RT / AE / GK – Channel support, connecting and gradient elements

Extra-slim hard foam channel support elements with integrated and sealed floor channel drain in three lengths, cover rail and frame made from stainless steel, cover rail in brushed stainless steel or tileable on the rear side. Incl. integrated horizontal drain connection fitting with odour trap. Height adjustable with height adaptor from 5–17 mm. All models can be combined with optionally available connecting elements TUB-LINE COMBI AE.

Hard foam gradient elements, square or rectangular, sealed, with 1-sided slope.

 <p>■ TUB-LINE COMBI RT 900 (650) with floor channel drain 70 x 650 mm, standard dimensions 200 x 900 x 67 mm.</p>	 <p>■ TUB-LINE COMBI RT 900 (750) with floor channel drain 70 x 750 mm, standard dimensions 200 x 900 x 67 mm.</p>	 <p>■ TUB-LINE COMBI RT 1200 (850) with floor channel drain 70 x 850 mm, standard dimensions 200 x 1200 x 67 mm.</p>	<p>■ TUB-LINE COMBI GK R1 1200/900 rectangular, standard dimensions 1200 x 900 x 70/85 mm.</p>
<p>■ TUB-LINE COMBI AE 900 Connecting element 120 x 900 x 67 mm for TUB-LINE COMBI RT 900.</p>	<p>■ TUB-LINE COMBI AE 900 Connecting element 120 x 900 x 67 mm for TUB-LINE COMBI RT 900.</p>	<p>■ TUB-LINE COMBI AE 1200 Connecting element 120 x 1200 x 67 mm for TUB-LINE COMBI RT 1200.</p>	<p>■ TUB-LINE COMBI GK Q1 1200 square, standard dimensions 1200 x 1200 x 70/85 mm.</p>

Programme summary

Point drainage

TUB – floor drain systems

The system of the TUB floor drains consists of three different floor drain supports, vertical or horizontal, which can be combined with eight grate variants (including grate fitting frame). Alternatively to the combinable floor drains the standard grates are available as a complete set with grate fitting frame and vertical or horizontal floor drain support.

To fit all LUX ELEMENTS®-TUB-shower base elements and shower drain element TUB-MQ-SET 300

Floor drain supports, combinable



■ **TUB-BA-W**
Floor drain support DN 50 horizontal, with odour trap



■ **TUB-BA-S**
Floor drain support DN 50 vertical, for 160 mm core drill hole, with odour trap



■ **TUB-BA-S 100**
Floor drain support DN 40/ DN 50, vertical, for 100 mm core drill hole, with odour trap

Floor drain supports, complete



■ **TUB-BAW-S**
Floor drain support DN 50 horizontal, with odour trap, incl. grate fitting frame made of ABS and standard stainless steel grate, universal height adjustment to suit tile thickness is possible



■ **TUB-BAS-S**
Floor drain support DN 50 vertical, for 160 mm core drill hole, with odour trap, incl. grate fitting frame made of ABS and standard stainless steel grate, universal height adjustment to suit tile thickness is possible



■ **TUB-BAS-S 100**
Floor drain support DN 40/ DN 50 vertical, for 100 mm core drill hole, with odour trap, incl. grate fitting frame made of ABS and standard stainless steel grate, universal height adjustment to suit tile thickness is possible

Grate variants

Standard grate



■ **TUB-RA-S**
Grate fitting frame made of ABS and standard stainless steel grate; universal height adjustment to suit tile thickness is possible

Design grate, with locking system



■ **TUB-RA-DS**
Grate fitting frame made from ABS, with frame and design grate 'Slot' made of stainless steel, universal height adjustment to suit tile thickness is possible, with locking system



■ **TUB-RA-DF**
Grate fitting frame made from ABS, with frame made of stainless steel and tileable plastic cover, universal height adjustment to suit tile thickness is possible, with locking system, thickness of surface covering (tile and adhesive) for the shower tray minimum 14 mm, for the tileable covering 11 mm

Design grate



■ **TUB-RA-DA**
Grate fitting frame made from ABS, with frame and design grate 'ANGOLO' made of stainless steel, universal height adjustment to suit tile thickness is possible



■ **TUB-RA-DC**
Grate fitting frame made from ABS, with frame and design grate 'CUBE' made of stainless steel, universal height adjustment to suit tile thickness is possible



■ **TUB-RA-DM**
Grate fitting frame made from ABS, with frame and design grate 'MARE' made of stainless steel, universal height adjustment to suit tile thickness is possible



■ **TUB-RA-DL**
Grate fitting frame made from ABS, with frame and design grate 'LUMEN' made of stainless steel, universal height adjustment to suit tile thickness is possible



■ **TUB-RA-DV**
Grate fitting frame made from ABS, with frame made of stainless steel and tileable cover 'VARI' made of stainless steel, universal height adjustment to suit tile thickness is possible, thickness of surface covering (tile and adhesive) for the shower tray minimum 5 mm, for the tileable covering 8 mm

Linear drainage

TUB-LINE – floor drain systems

The matching floor drain support is available as a vertical or horizontal model.



■ **TUB-BA-W**
Floor drain support DN 50, horizontal, without odour trap



■ **TUB-BA-S**
Floor drain support DN 50, vertical, for 160 mm core drill hole, without odour trap

LUX ELEMENTS – The Experience

Shower bases

Further areas of application

TUB-PL – for alternative water-resistant coverings, made to measure

Hard foam shower base element with higher compressive strength to accommodate alternative water-resistant coverings (web materials such as e.g. PVC or coatings). Matching drain technology (optional) with grate fitting frame and grate as well as a vertical or horizontal floor drain support DN 50 with odour trap. Two variants are offered depending on the type of covering.

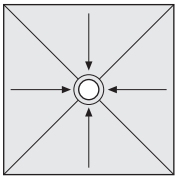

■ TUB-PL-B + drain technology for web material

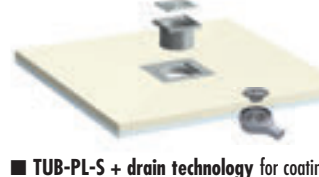

■ TUB-PL-S + drain technology for coatings

TUB-PUMP – flush with the floor shower bases with integrated floor drain pump

Hard foam shower base element with integrated and sealed-in floor drain pump, incl. 2 substrate elements, square or rectangular, cover from stainless steel, cover tileable on the rear side.

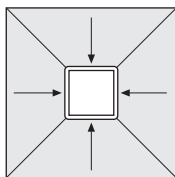

■ TUB-PUMP MQ 900
square, standard dimensions 900 x 900 x 30/45 mm, drain in the centre.

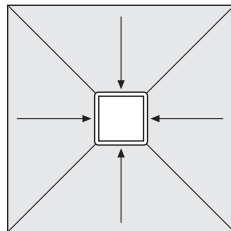

■ TUB-PUMP MQ 1200
square, standard dimensions 1200 x 1200 x 30/45 mm, drain in the centre.

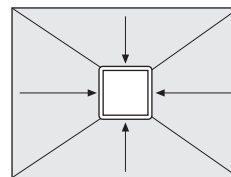

■ TUB-PUMP MR 1200/900
rectangular, standard dimensions 1200 x 900 x 30/45 mm, drain in the centre.

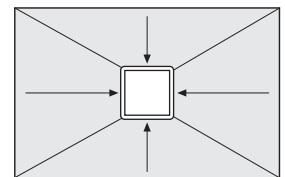

■ TUB-PUMP MR 1400/900
rectangular, standard dimensions 1400 x 900 x 30/45 mm, drain in the centre.

TUB-WALL – shower drain element with integrated wall drain

Hard foam shower drain element with integrated wall drain, with tileable cover from stainless steel, with odour trap.



■ TUB-WALL RT 1 900/200
200 x 900 x 70 mm, with 1-sided slope, including loose sealing sleeve 370 x 1300 mm



■ TUB-WALL RT 1 1200/200
200 x 1200 x 70 mm, with 1-sided slope, including loose sealing sleeve 370 x 1300 mm

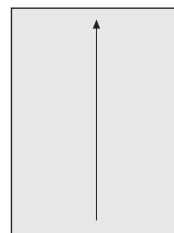

■ TUB-LINE COMBI GK R1 1200/900
Gradient element, rectangular, standard dimensions 1200 x 900 x 70/85 mm, sealed, with 1-sided slope

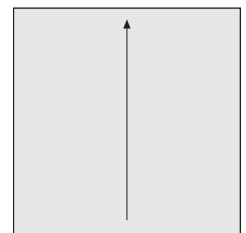

■ TUB-LINE COMBI GK Q1 1200
Gradient element, square, standard dimensions 1200 x 1200 x 70/85 mm, sealed, with 1-sided slope



■ TUB-WALL RT 3 900/200
200 x 900 x 70/85 mm, with 3-sided slope, including loose sealing sleeve 370 x 1300 mm



■ TUB-WALL RT 3 1200/200
200 x 1200 x 70/85 mm, with 3-sided slope, including loose sealing sleeve 370 x 1300 mm

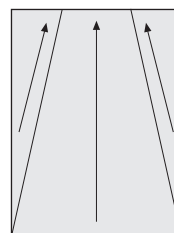

■ TUB-LINE COMBI GK R3 1200/900
Gradient element, rectangular, standard dimensions 1200 x 900 x 70/85 mm, sealed, with 3-sided slope

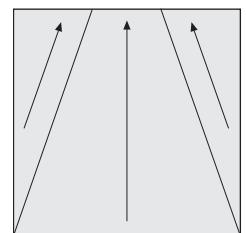

■ TUB-LINE COMBI GK Q3 1200
Gradient element, square, standard dimensions 1200 x 1200 x 70/85 mm, sealed, with 3-sided slope

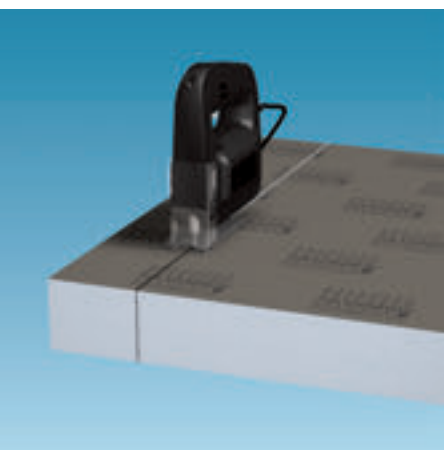

Technical data and accessories

Shower bases by LUX ELEMENTS captivate not only by their design – the technology is also carefully conceived. The results are safe, reliable products for almost any installation situation.

The technical details include: function and performance of the drain system, descending gradients and installation heights of the shower bases, and special technical characteristics of the individual models. In addition there are tips on sealing a shower area as well as an overview of all system components for installation. Because knowledge creates confidence!

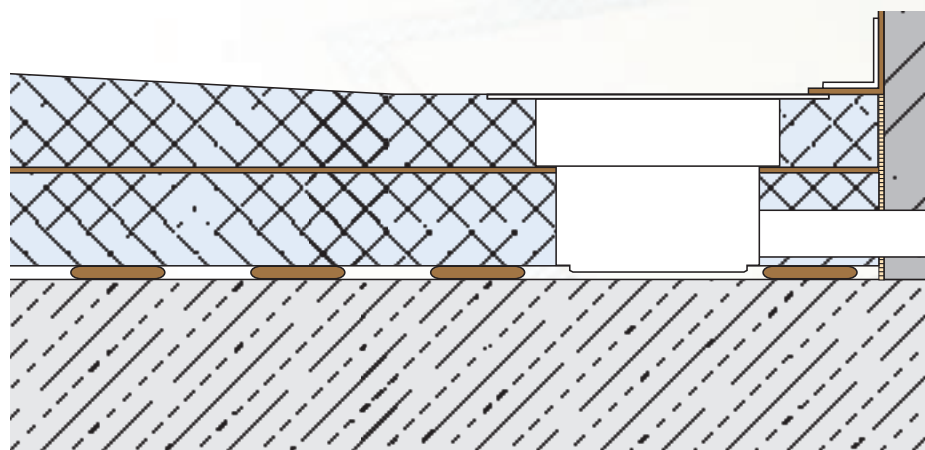
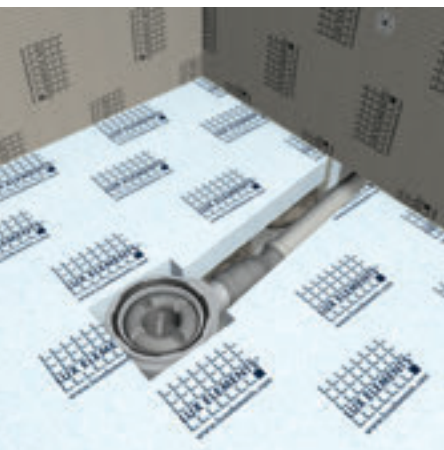

LUX ELEMENTS – The Experience

Shower bases



Drain technology



Point drainage with a simple click-system

The drain system for point drainage consists of a floor drain support easy-to-install with a click-system, vertical (DN 50 for 160 mm core drill hole or DN 40/50 for 100 mm core drill hole) or horizontal, with odour trap, plus grate fitting frame made of ABS and standard or design grate made of stainless steel. Universal height adjustment to the covering thickness is possible (see page 56).

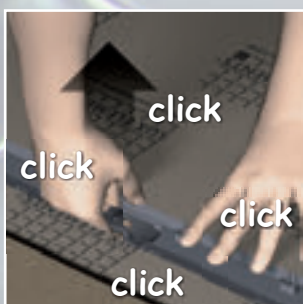

Linear drainage with a simple click-system

The standard drain system for linear drainage consists of an easy-to-install floor drain support vertical (DN 50 for 160 mm core drill hole) or horizontal, with odour trap. The somewhat narrower odour trap is already integrated into the channel, so that only the drain connection fitting is to be installed with a simple click-system.

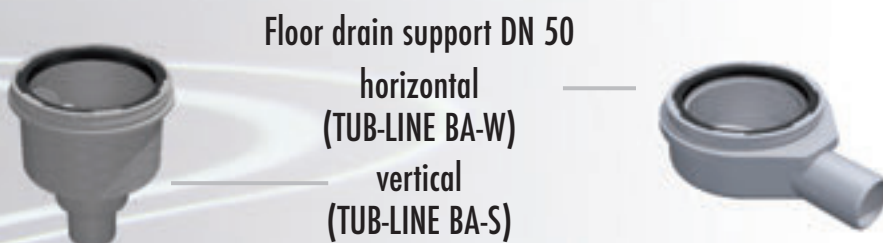

LUX ELEMENTS – The Experience

Shower bases

Compatible accessories

Useful accessories are available for both drain systems, point and linear drainage.

Multistop as protection

TUB-BAZ STOP + TUB-LINE BAZ STOP: Odour, foam and vermin barrier can also be retro-fitted to existing installed drains. The drain is prevented from drying out by the tightly sealing cap, thus also preventing the formation of unpleasant odours. Recommendable in particular for irregularly used showers, e.g. in weekend homes.

The multistop works simply according to the principle of the force of gravity.



ill. KESSEL

Hair trap for a clean drain

TUB-BAZ HS + TUB-LINE BAZ HS: The practical hair trap reliably collects hair and dirt and prevents any blockage in the drain pipe. It can be easily removed and cleaned using two small tongues. Can also be retrofitted in already installed drains.



Adaptors for the international market

TUB-BAZ DN 50/40: reducer, DN 50 to DN 40, made of ABS with lip seal.

TUB-BAZ BST: adaptor, DN 50 to British Standard BST, made of PVC. An adaptor for the Swiss market is available from us on request.



One elbow for many angles

TUB-BAZ HTK: HTK elbow, DN 50, swivel joint 0–87° (infinite). Due to integrated swivel joint, replaces six conventional HT elbows from 0 to 87°, hence significantly reducing stock levels. Simple, fast assembly.

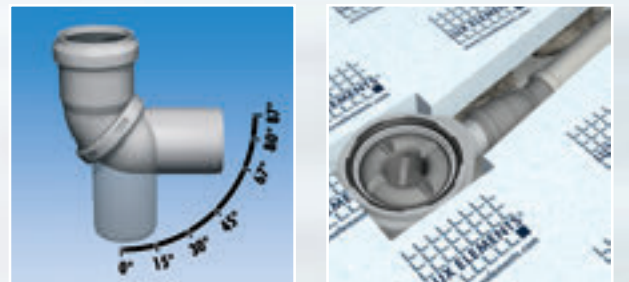

Fire protection set for more safety

TUB-BAS-S FIRE STOP: Floor drain support DN 50 for 160 mm core drill hole, vertical, with odour trap, including grate fitting frame made of ABS and standard stainless steel grate, including extension piece TUB-BAZ VER and fire protection insert.

TUB-LINE BA-S FIRE STOP: Floor drain support DN 50 vertical for 160 mm core drill hole, with odour trap, incl. adaptor part TUB-BAZ VER and fire-protection component

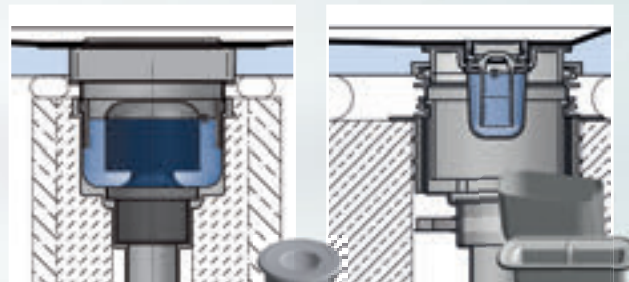

Extension piece facilitates connection

TUB-BAZ VER: separately available extension piece for the floor drain supports for 160 mm core drill hole.



Fire protection seal against flames and smoke

TUB-BAZ DGD: Conduit seal for 160 mm core drill hole, with fire protection in conjunction with TUB-... FIRE STOP.

More accessories upon request

Installation heights

Point drainage

■ TUB – flush with the floor shower bases

The flush with the floor shower bases for point drainage have a height of 30/45 mm with an integrated gradient, the substrate element is 55 mm high. This results in an **installation height starting at 45 mm** – ideal also for the renovation of old buildings.

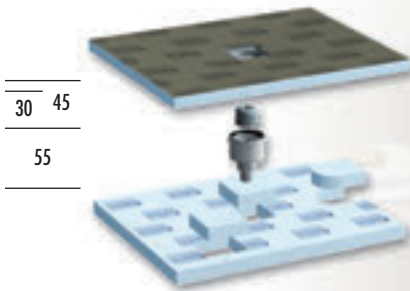
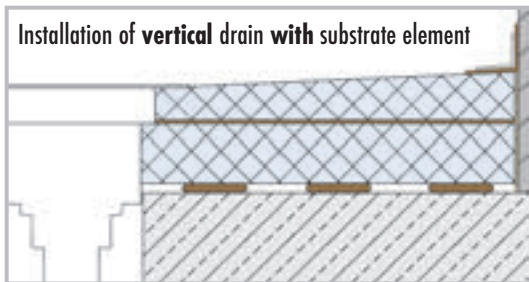
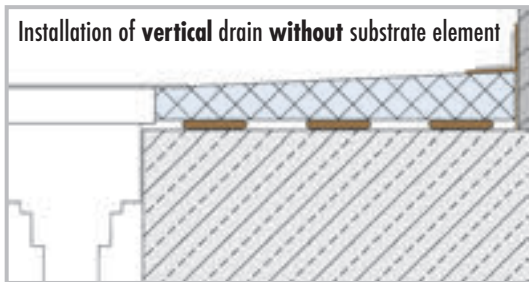
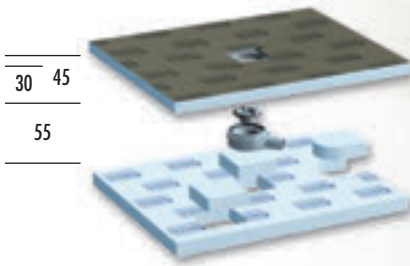
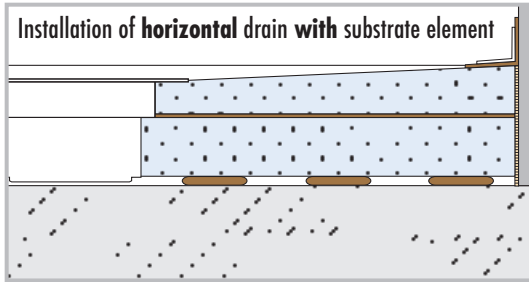

NOTE:
The substrate element can be omitted upon installation of the vertical drain. The installation height is then only 45 mm.

■ TUB-MQ-SET 300 – shower drain element

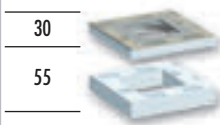
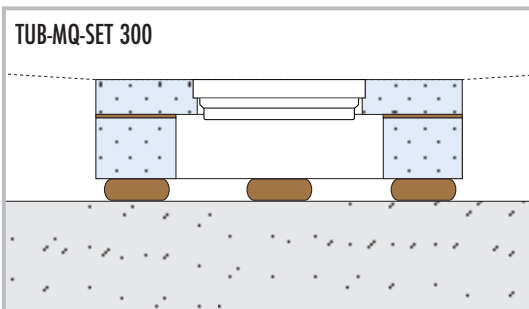

Note: Dimensions in mm. Measures without adhesive coating and tiles.

LUX ELEMENTS – The Experience

Shower bases

Linear drainage

■ TUB-LINE – flush with the floor shower bases

In the TUB-LINE flush with the floor showers for linear drainage, the installation height and the slope type (single-sided or 4-sided) vary depending on the application and/or subsequent tile design. With all products, safety and flexibility are the joint priority, both for the installation and for the subsequent tiling.

Installation of **horizontal drain with substrate element**

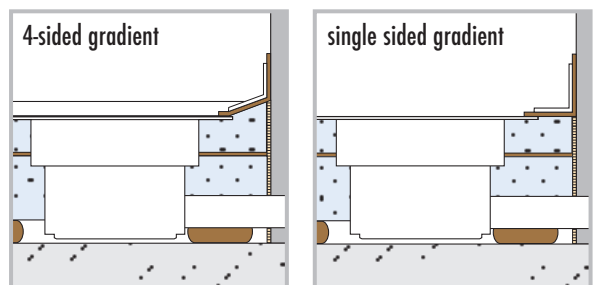

Installation of **vertical drain without substrate element**

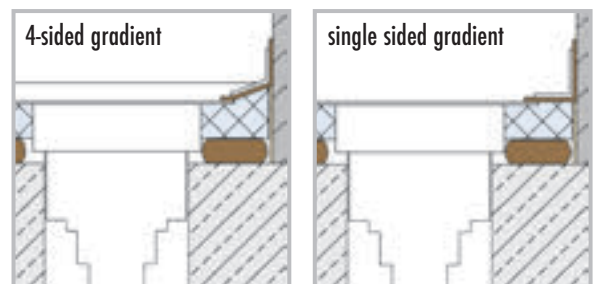

■ TUB-LINE RT/GK – channel supports and gradient elements

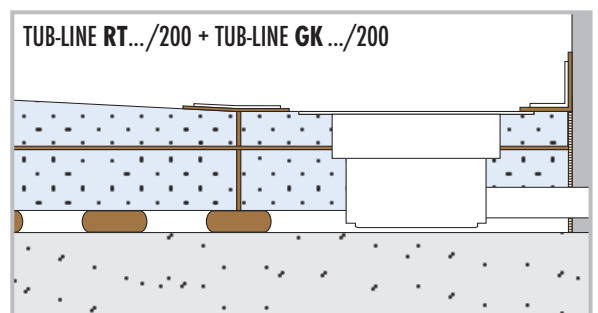

Note: Dimensions in mm. Measures without adhesive coating and tiles.

If necessary, the gradient elements can be cut to size on the higher side to adapt them e.g. to a niche.

Installation heights

Point drainage

■ TUB-BOL – flush with the floor shower bases as a substitute for bath tubs

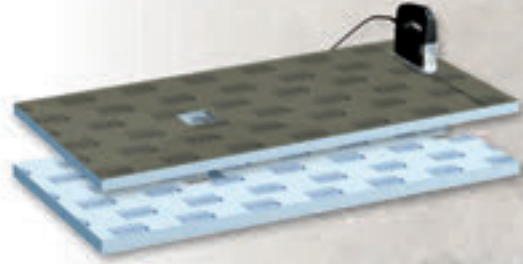
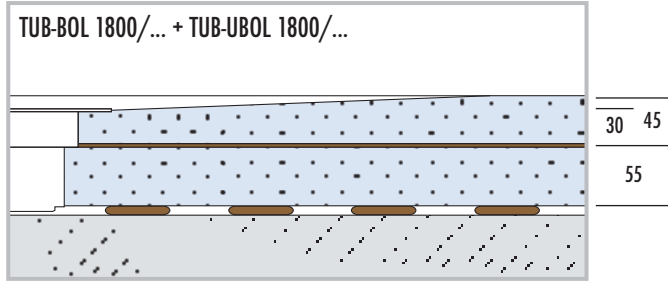

NOTE:
The substrate element can be omitted upon installation of the vertical drain. The installation height is then only 45 mm.

■ TUB-H – flush with the floor shower bases on wooden sub-constructions

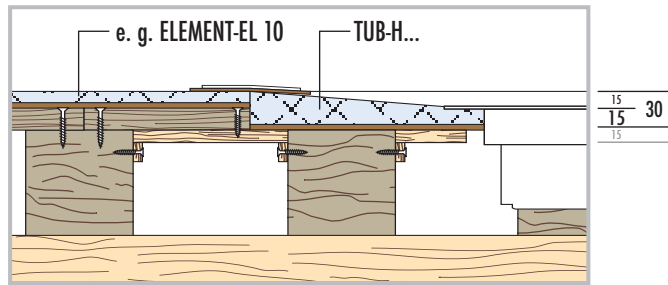

■ TUB-COMBI – flush with the floor shower bases, integrated drain system

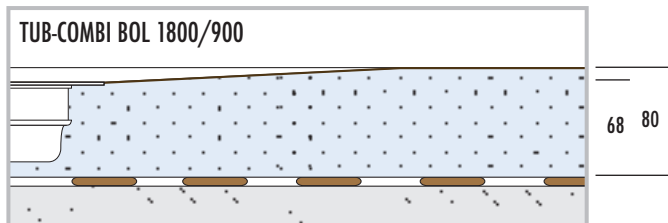
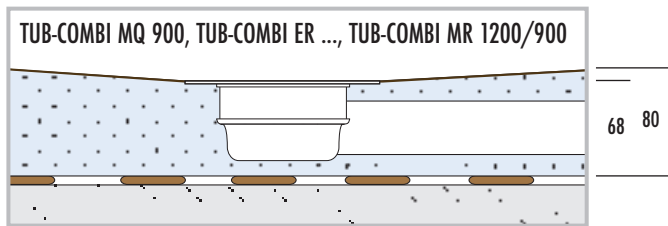

■ TUB-COMBI MQ 300 – shower drain element, integrated drain system

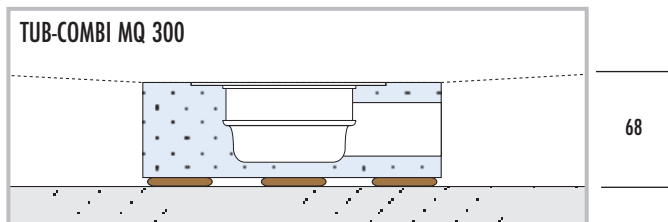

Note: Dimensions in mm. Measures without adhesive coating and tiles.

LUX ELEMENTS – The Experience

Shower bases

Linear drainage

- **TUB-LINE BOL** – flush with the floor shower bases as a substitute for bath tubs

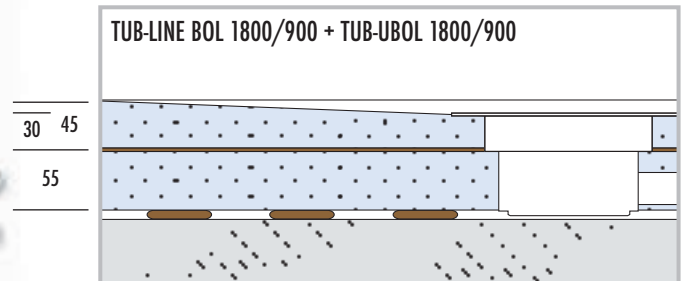

- **TUB-LINE H** – flush with the floor shower bases on wooden sub-constructions

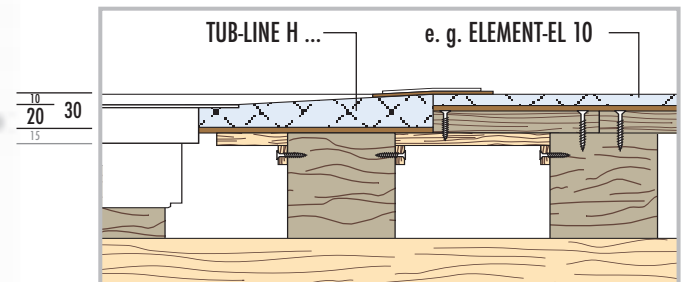
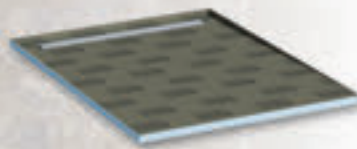

- **TUB-LINE COMBI** – flush with the floor shower bases, integrated drain system

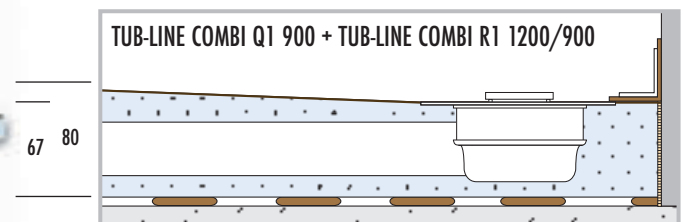
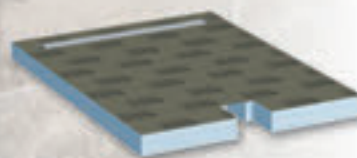
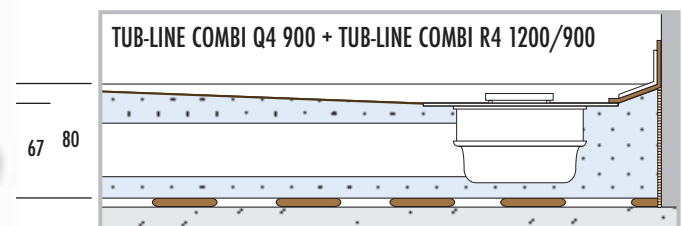
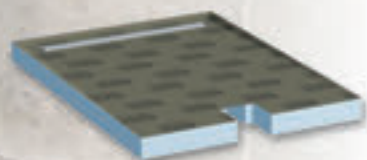

- **TUB-LINE COMBI RT / AE / GK** – Channel support, connecting and gradient elements

If necessary, the gradient elements can be cut to size on the higher side to adapt them e.g. to a niche.

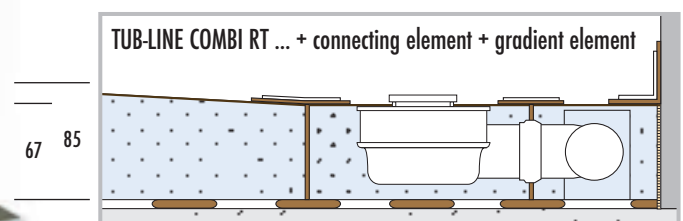
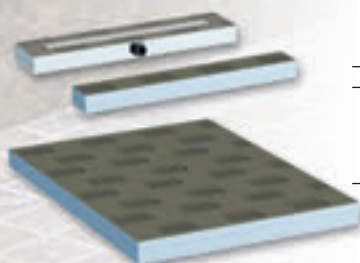

Note: Dimensions in mm. Measures without adhesive coating and tiles.

All about water

Things worth knowing about drainage

Flow rates of commercially available shower heads



Normal manual shower heads

... mostly lie between 2.5 and 25 l/min without a water saving device.



Fixed shower heads

... have widely differing flow rates from 5 to 35 l/min.

The rate can usually be preset.



Raindrop showers

... have a flow rate of up to approx. 40 l/min.

The rate varies widely with the plate size and manufacturer.



Side sprinklers

... also have widely differing flow rates from 5 to 13 l/min depending on the manufacturer.



A flow rate from 35 to 65 l/min. is recommended for **flood showers**.

Of course, there are also larger manufacturer-dependent flow rates here.

When planning the shower area the selection of fittings should already be included. The drainage capacity of the shower base must meet the flow rate of the selected shower head, so that the water can drain away quickly and not accumulate.

Safety is therefore guaranteed with all TUB drain systems by LUX ELEMENTS, since they can easily cope with these flow rates and the water drains off without any problems.

■ NOTE:

For further information, please refer to our documents. Data sheets, test certificates and processing instructions can be downloaded from www.luxelements.com

(All data are measured at 3 bar flow pressure)

LUX ELEMENTS – The Experience

Shower bases











Drainage capacities

Point drainage

High drainage capacity enables shower fittings with large flow rates

The high drainage rate is one of the technical strengths of the drain system in the TUB product range. With rates of up to 102 l/minute, rain or power shower heads can be used without any problems. The capacity may vary according to the design, accessories and drain grate.

Drainage capacities of the shower bases TUB, TUB-H and TUB-BOL

Floor drain system with standard odour trap	Grate variant							
	standard	design					design, with locking system	
	 RA-S	 RA-DA	 RA-DC	 RA-DM	 RA-DL	 RA-DV	 RA-DF	 RA-DS
horizontal DN 50 TUB-BA-W 	60 l/min	66 l/min	72 l/min	72 l/min	66 l/min	78 l/min	60 l/min	60 l/min
vertical DN 50 TUB-BA-S 	102 l/min	84 l/min	78 l/min	96 l/min	90 l/min	96 l/min	96 l/min	102 l/min
vertical DN 50 TUB-BA-S 100 	72 l/min	66 l/min	66 l/min	72 l/min	66 l/min	72 l/min	72 l/min	72 l/min

Drainage capacities of the shower bases TUB-COMBI MQ/ER/MR and TUB-COMBI BOL

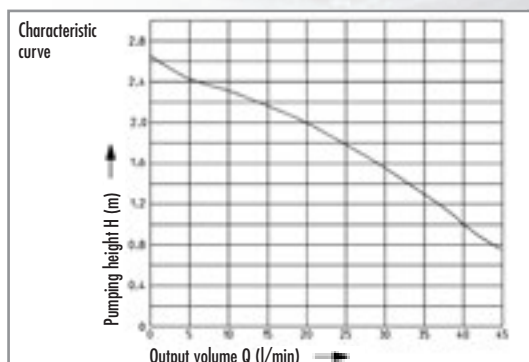

Floor drain system	Grate variant
integrated floor drain horizontal DN 50 with odour trap 	standard 60 l/min

Drainage capacities of the shower bases TUB-PUMP



Linear Drainage

The capacity may vary according to the accessories (see page 49).

Floor drain system	Type of channel	
	TUB-LINE	TUB-LINE-COMBI
horizontal DN50 TUB-LINE BA-W 	48 l/min	31 l/min
vertical DN50 TUB-LINE BA-S 	48 l/min	—

Tile covering

Possible cover thickness levels

Point drainage

The height of the tile covering varies depending on the drain system and the grate used:

Upper layer thickness ≥ 5 mm



Upper layer thickness (tile + adhesive) for the shower base at least 5 mm

Standard grate*



■ TUB-RA-S

Design grate*
'ANGOLO', 'CUBE', 'MARE', 'LUMEN'



■ TUB-RA-DA



■ TUB-RA-DC



■ TUB-RA-DM



■ TUB-RA-DL

Design grate*,
with locking system



■ TUB-RA-DS

Upper layer thickness ≥ 5 mm / tileable cover = 8 mm



Upper layer thickness (tile + adhesive) for the shower base at least 5 mm, for the tileable cover = 8 mm

Design grate* 'VARI', tileable



■ TUB-RA-DV

NOTE:

A top covering thickness of 12 mm is necessary when using TUB-RA-DV with a model from the TUB-COMBI range.

Upper layer thickness ≥ 14 mm / tileable cover = 11 mm



Upper layer thickness (tile + adhesive) for the shower base at least 14 mm, for the tileable cover = 11 mm

Design grate**, tileable and with locking system



■ TUB-RA-DF

NOTE:

A top covering thickness of 20 mm is necessary when using TUB-RA-DF with a model from the TUB-COMBI range.

Linear drainage

Upper layer thickness ≥ 5 mm / tileable channel cover = 12 mm



Upper layer thickness (tile + adhesive) for the shower base minimum 5 mm, maximum 17 mm, for the tileable stainless steel channel cover = 12 mm

LUX ELEMENTS – The Experience

Shower bases

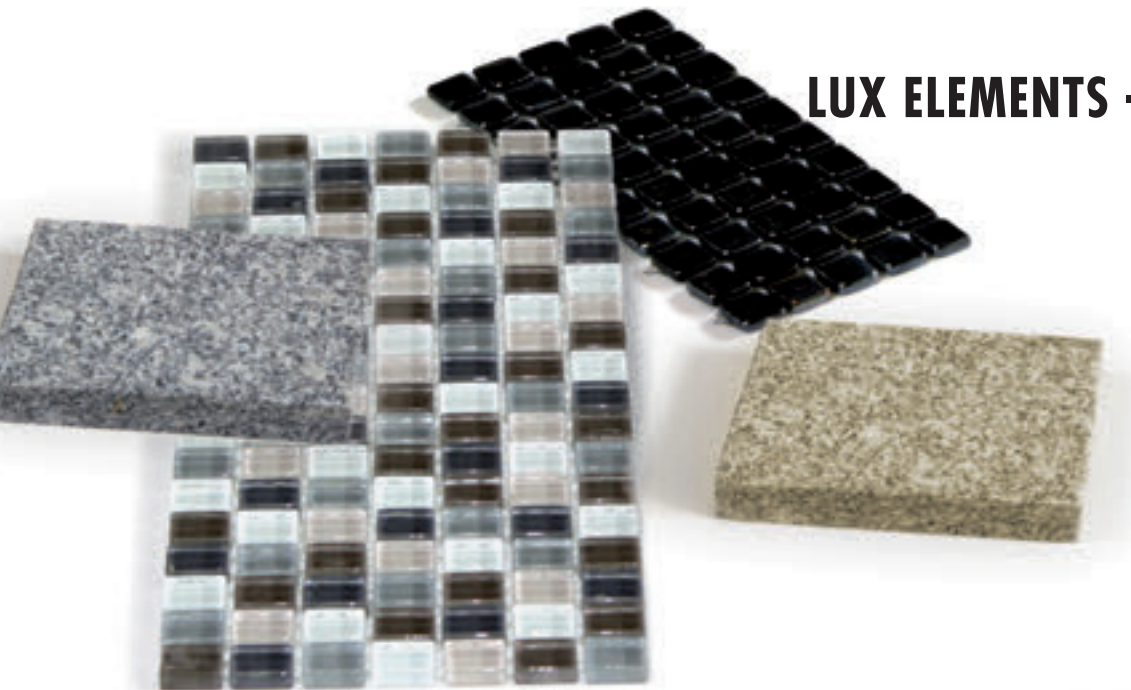

Optimum height adjustment to covering thickness

Point drainage

Easy shortening of the grate fitting frame with grooved structure (suitable for the design grates ANGOLO, CUBE, MARE, LUMEN, VARI and the standard grate) to adapt to the covering thickness: first groove for 5 mm mosaic, further grooves approximately every 3 mm.

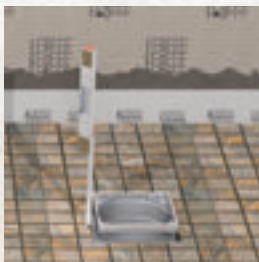

Linear drainage



Separately provided adapters that can be cut as required enable **height adjustability of the channel** for surface covering thicknesses from 5 to 17 mm.

Hence, both mosaic and thicker natural stone can be used for tiling. This means a great deal of freedom when designing the surface.



Mosaic $\geq 20 \times 20$ mm with front-mount adhesive film can be used as the lining for **both low exposures and heavier loads** of up to 200 kg (e.g. wheelchair use) so long as a reaction resin is used for gluing and joining.

If the **size of the tiles is $\geq 50 \times 50$ mm**, tile adhesive of quality grade C2 can be used for gluing and a cementitious grout material for joining. Please take note of our General Building Authority Approved Test Certificate No. P-AB/20802/ 05-2008 from tBU GmbH when covering our shower base elements with surface materials.

Ensure that the tiles/mosaic pieces have a sufficient breaking strength. The shower base element should not be **subjected to loads greater than 0.1 N/mm^2** .

Processing



The processing of LUX ELEMENTS shower base elements is simple, fast and clean.

On our homepage at www.luxelements.com under Service/Downloads, you will find detailed installation instructions as well as installation videos.

Tools

The hard foam shower base elements from LUX ELEMENTS are easy to use. Simple tools, which are included in any ordinary tool box, are suitable for installation.

For cuts and notches, we recommend:



- Angle grinder with segmented diamond wheel
- Jack saw, serrated saw blade
- Cutter

Other important accessories are:

- Spirit Level
- Folding ruler
- Pencil
- Screwdriver
- File for filing the grate fitting frame after height adjustment (see page 55)
- Silicone for the sealing of e.g. connections
- Cartridge gun for pressing out glue cartridges

“Classical tiling tools” are used for the application of bonding agents:

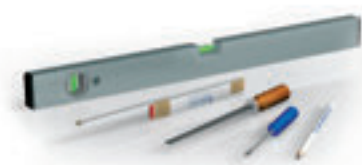
- Bricklayer’s trowel
- Smoothing trowel
- Notched trowel

TUB-KIT UNI

Contents:

- 5,0 kg COL-AK
- 3,5 kg DRY-ASK
- 10 m DRY-DB
- 2 x DRY-DBIE

Assembly KITS for all models

Three assembly KITS are offered for the installation of the shower bases, containing all necessary mounting materials. In order to determine the correct KIT, not only the size of the shower base is decisive, but also the processing method. Here we differentiate between full-surface adhesion or adhesion on dots.



TUB-KIT UNI GK

Contents:

- 3 x 5 kg COL-AK
- 3,5 kg DRY-ASK
- 10 m DRY-DB
- 2 x DRY-DBIE



TUB-KIT UNI GG

Contents:

- 5 x 5 kg COL-AK
- 3,5 kg DRY-ASK
- 10 m DRY-DB
- 2 x DRY-DBIE

Table overview of assembly KITS

Application ranges for TUB-KIT UNI, TUB-KIT UNI GK, TUB-KIT UNI GG					
Length TUB a in mm	Length TUB b in mm	without substrate element, full surface	without substrate element, on 15 mm dots	with substrate element, full surface	with substrate element, on 15 mm dots
900	900	TUB-KIT UNI	TUB-KIT UNI GK	TUB-KIT UNI	TUB-KIT UNI GK
1000	800	TUB-KIT UNI	TUB-KIT UNI GK	TUB-KIT UNI	TUB-KIT UNI GK
1000	1000	TUB-KIT UNI	TUB-KIT UNI GK	TUB-KIT UNI	TUB-KIT UNI GK
1200	1200	TUB-KIT UNI	TUB-KIT UNI GK	TUB-KIT UNI GK	TUB-KIT UNI GG
1400	1400	TUB-KIT UNI GK	TUB-KIT UNI GG	TUB-KIT UNI GK	TUB-KIT UNI GG
1500	1500	TUB-KIT UNI GK	TUB-KIT UNI GG	TUB-KIT UNI GK	TUB-KIT UNI GG
2000	1000	TUB-KIT UNI GK	TUB-KIT UNI GG	TUB-KIT UNI GK	TUB-KIT UNI GG

LUX ELEMENTS – The Experience

Shower bases

LUX ELEMENTS®-System components



■ **LUX ELEMENTS®-DRY-ASK – Filling wall and floor surfaces**
Single-component, water-impermeable, crack-bridging and flexible sealing compound and is particularly suitable for sealing LUX ELEMENTS® hard foam support elements.



■ **LUX ELEMENTS®-DRY-DB – Integrating sealing tape into wall/floor connections**
Extremely thin, tear-resistant special fleece for sealing. Suitable for all connection seals occurring in conjunction with DRY-ASK or DRY-DF.

■ **LUX ELEMENTS®-DRY-DBV – Sealing tape**
... with additional vapour-retardant properties



■ **LUX ELEMENTS®-DRY-DBWM – Sealing pipe ducts**
Wall sleeves for the sealing of pipe ducts.

■ **LUX ELEMENTS®-DRY-DBBM – Sealing floor drains**
Floor sleeves for the sealing of floor drains.

Seals

For sealing in the shower area, a large selection of products from the product range LUX ELEMENTS®-DRY is available.

LUX ELEMENTS®-DRY are sealing tapes, films and fillers for producing waterproof substrates.

Applications:

- Wall/floor connections
- Inner corners
- Outer corners
- Pipe ducts
- Floor drains

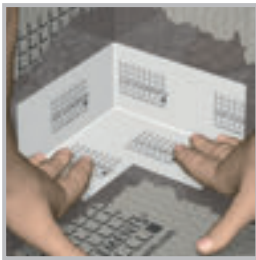

■ **LUX ELEMENTS®-DRY-DBIE – Forming inner corners**

■ **LUX ELEMENTS®-DRY-DBVIE – Inner corners**
... with additional vapour-retardant properties

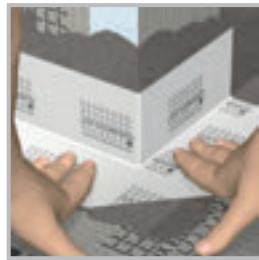

■ **LUX ELEMENTS®-DRY-DBAE – Forming outer corners**

■ **LUX ELEMENTS®-DRY-DBVAE – Outer corners**
... with additional vapour-retardant properties



■ **LUX ELEMENTS®-DRY-DBDZM – Expansion zone sleeve**

On PU basis. Two different sizes having a central expansion zone to enable pipes of different external diameters to be sealed. Installation in combination with DRY-ASK.

Adhesives

The product range LUX ELEMENTS®-COL contains mortar and adhesives for the processing of hard foam support elements. These products are suitable for processing shower bases:



■ **LUX ELEMENTS®-COL-AK – Fixing adhesive**
A ready-mixed dry mortar for the attaching and adhesion of LUX ELEMENTS® hard foam support elements. COL-AK is: stable, fast bonding, frost-proof, waterproof.



■ **LUX ELEMENTS®-COL-FLEX – Bonding mortar**
COL-FLEX is a flexible cement powder adhesive and is used in particular for laying onto LUX ELEMENTS® hard foam support elements, alternative seals (DRY-ASK) or substrates where stresses are a possibility.



■ **LUX ELEMENTS®-COL-MK – Mounting adhesive**
COL-MK is a moisture cross-linking, single-component adhesive on an STP polymer basis for the gluing of LUX ELEMENTS® hard foam support elements. Furthermore, COL-MK adheres to various substrates such as metals, wood materials, ceramics, glass and other building materials.



■ **LUX ELEMENTS®-COL-HSV Primer**
Solvent-free dispersion primer, primarily suitable for wooden substrates.

Sealing of the shower area

No other sealing must be applied to the shower base! All shower bases are equipped with a factory-fitted sealing and an integrated and sealed-in fitting frame for the floor drain or a sealed-in channel drain. This means that the drain need no longer be separately sealed in.

Test certificate no. P-AB/20802/05.1-2008 dated 19.02.2008 was issued for the product LUX ELEMENTS®-TUB by the Institute for textile building and environment technology (tBU).



Production of a sealing in combination with tile coverings and pavings using LUX ELEMENTS®-TUB as a sealing system acc. to Building Rules List A Part 2, no. 2.50 and exposure class A2



ETA-13/0238
LUX ELEMENTS®
WATERTIGHT SOLUTION
COMPONENT 3.2/8
www.luxelements.com

NOTE:

Please also observe the approvals for our products in accordance with the national directives. These are constantly being extended.

You can view the current status of all documents applicable for your country under "Downloads" at www.luxelements.com or simply contact us.

All from one source: LUX ELEMENTS offers all components for the entire shower area: starting from the shower base over the wall installation through to all required sealing materials for the transitions. All in all, this results in a perfectly coordinated and tested system.

The advantages for the installer are:

- High degree of safety
- No falling below the minimum layer thickness
- Construction and sealing in one

Basic design principle of a shower area with

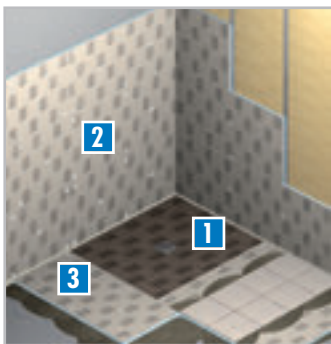

... with LUX ELEMENTS®-ELEMENT-EL:

- 1 TUB – Floor structure with shower base flush with the floor, factory sealing
- 2 ELEMENT-EL – wall structure on masonry, concrete or plaster, wooden or metal stud frame or free-standing with waterproof construction panel.
- 3 ELEMENT-EL – Floor structure on wooden floor or mineral substrate



In non-public areas it is possible to create a bond using LUX ELEMENTS®-COL-MK mounting adhesive for wall installation, which simultaneously serves as a sealing.

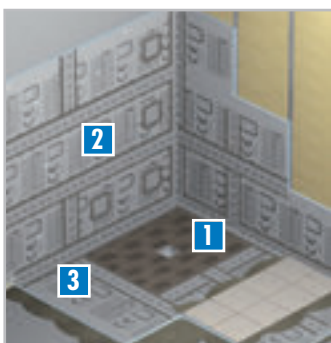

... with LUX ELEMENTS®-ELEMENT-VK:

- 1 TUB – Floor structure with shower base flush with the floor, factory sealing
- 2 ELEMENT-VK – Wall structure on masonry, concrete or plaster, wooden or metal stud frame or free-standing with plate-type composite sealing
- 3 ELEMENT-VK – Floor structure on wooden floor or mineral substrate

Further requirements regarding sealing elements must be taken into consideration in accordance with national directives (see: types of seals page 61).

LUX ELEMENTS – The Experience

Shower bases

Today we differentiate between three different types of composite sealing:

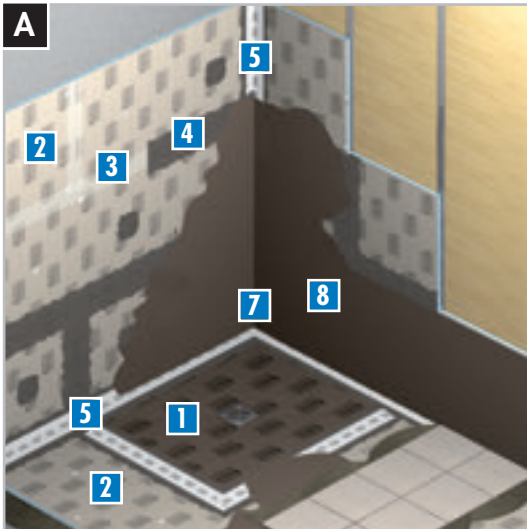

Liquid sealings

for use with the following products:

- 1 TUB – flush with the floor shower base
- 2 ELEMENT-EL – waterproof construction panel
- 3 ARM-100 SK – reinforcing fabric for joints
- 4 COL-AK – fixing adhesive for levelling out the reinforced joints
- 5 DRY-DB – sealing tape for transitions
- 6 DRY-ASK – sealing filler for sealing in the sealing tapes
- 7 DRY-DBIE – sealing tape as a shaped part “inner corner”
- 8 DRY-ASK – sealing filler, full-surface

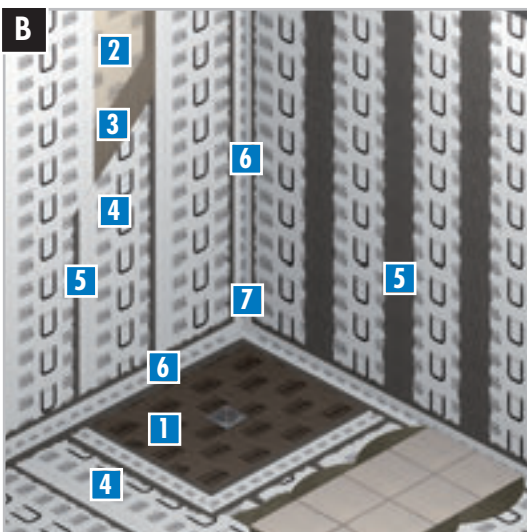

Web-type sealings

for use with the following products:

- 1 TUB – flush with the floor shower base
- 2 ELEMENT-EL – waterproof construction panel
- 3 COL-FLEX – mineral adhesive for the bonding of sealing film
- 4 DRY-DF – sealing film
- 5 DRY-ASK – sealing filler for bonding and sealing in the sealing film and sealing tapes
- 6 DRY-DB – sealing tape for transitions
- 7 DRY-DBIE – sealing tape as a shaped part “inner corner”

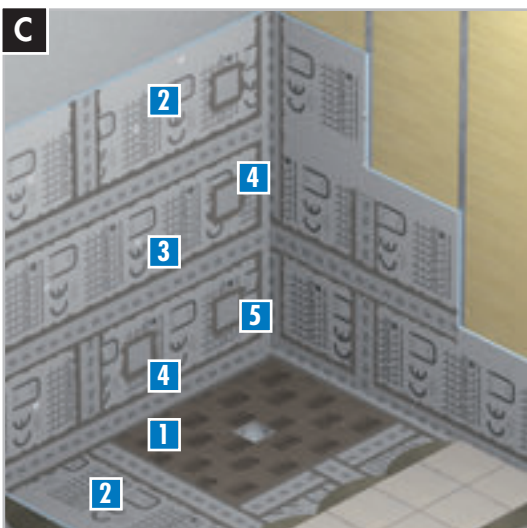

Plate-type sealings

are used with the following products:

- 1 TUB – flush with the floor shower base
- 2 ELEMENT-VK – plate-type composite sealing
- 3 DRY-ASK – sealing filler for sealing in the sealing tapes
- 4 DRY-DBV – sealing tape for transitions
- 5 DRY-DBVIE – sealing tape as a shaped part “inner corner”

This wall structure also acts as a vapour barrier
(sd value approx. 85 m)

Optional accessories

Impact sound insulation for flush with the floor shower bases

To increase the feeling of wellbeing and avoid noise by water – e.g. in multiple-family houses, nursing homes or hotels – we recommend impact sound insulation.

With the impact sound insulating mat TUB-TSM, LUX ELEMENTS offers the right solution. The product fulfils the requirements of DIN 4109/A1 and has been tested acc. to SIA 181.

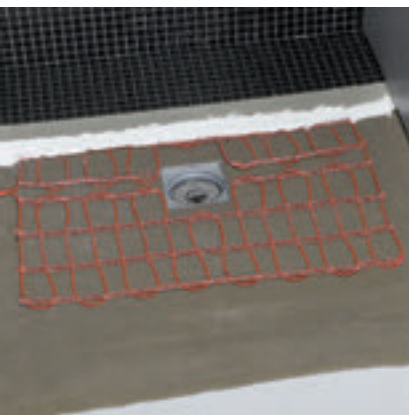

Heating of LUX ELEMENTS shower bases

Shower base elements from LUX ELEMENTS can be optionally heated. For this, we recommend e.g. electric thin-bed heating mats.

From the designer shower to the individual spa oasis

Do you like the designer shower building kits by LUX ELEMENTS? **We can do even more!** LUX ELEMENTS manufactures individual objects in the spa, health and leisure areas, such as steam baths, whirlpools, Kneipp basins or swimming pool linings. Round shapes are also possible. Everything from one source, ready to be tiled or plastered.

We will be only too pleased to inform you about the possibilities offered by hard foam support elements. Request our product range brochure. Just use the fax order form overleaf.



Thank you for your interest in LUX ELEMENTS products!

LUX ELEMENTS – The Experience

Shower bases

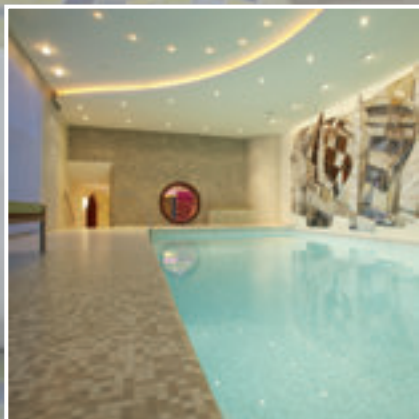

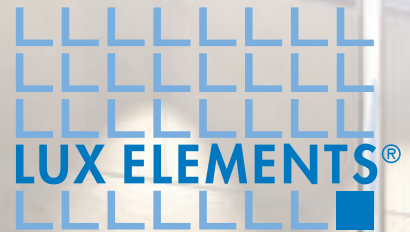

+49 (0) 21 71 / 72 12 10

Fax order form

Order more information

(Please enter the quantity and desired language!)

- | | | |
|--|--|---|
| ■ PRICE LIST (DE/EN/FR/NL) | <input type="checkbox"/> ___ pcs. / <input type="checkbox"/> PDF (E-Mail) | |
| ■ PROGRAM | <input type="checkbox"/> ___ pcs. / <input type="checkbox"/> PDF (E-Mail) | <input type="radio"/> DE <input type="radio"/> FR <input type="radio"/> NL <input type="radio"/> EN |
| ■ THE CONSTRUCTION – Designing with hard foam support elements | <input type="checkbox"/> ___ pcs. / <input type="checkbox"/> PDF (E-Mail) | <input type="radio"/> DE <input type="radio"/> FR <input type="radio"/> NL <input type="radio"/> EN |
| ■ THE EXPERIENCE – Shower bases | <input type="checkbox"/> ___ pcs. / <input type="checkbox"/> PDF (E-Mail) | <input type="radio"/> DE <input type="radio"/> FR <input type="radio"/> NL <input type="radio"/> EN |
| ■ INDIVIDUAL CONCEPTS – Customised and special products | <input type="checkbox"/> ___ pcs. / <input type="checkbox"/> PDF (E-Mail) | <input type="radio"/> DE <input type="radio"/> FR <input type="radio"/> NL <input type="radio"/> EN |
| ■ DETAILED DESCRIPTIVE LITERATURE | <input type="checkbox"/> ___ pcs. | <input type="radio"/> DE <input type="radio"/> FR <input type="radio"/> NL <input type="radio"/> EN |
| ■ ADVICE | <input type="checkbox"/> Yes, I am interested in an appointment, please call me. | |

SECTOR: Architect Tile retailer Tile installer Building materials retailer
 Plumber Bathroom designer Installer Others

COMPANY: _____

CONTACT: _____

ADDRESS: _____

POSTAL CODE/TOWN: _____

TEL: _____

FAX: _____

E-MAIL: _____



The EUF (European Union of National Tile Associations) has developed the concept "Healthier Living with Ceramics" together with its European member associations and sponsor members. This concept is intended as information "pro tile" for trade, dealers and manufacturers. LUX ELEMENTS is the force behind the project and is actively involved in its implementation.

(D)

LUX ELEMENTS GmbH & Co. KG

An der Schusterinsel 7

D - 51379 Leverkusen-Opladen

Tel. +49 (0) 21 71/72 12-0

Fax +49 (0) 21 71/72 12-10

info@luxelements.de

www.luxelements.com

(F)

LUX ELEMENTS S.A.S

ZI-31, rue d'Ensisheim

F - 68190 Ungersheim

Tél. +33 (0) 3 89 83 69 79

Fax +33 (0) 3 89 48 83 27

info@luxelements.fr

www.luxelements.fr

SHOWER BASES - EN-4/2016 - PROS5162
We reserve the right to make technical changes.