

**Product Description**

LUX ELEMENTS®-TUB-COMBI shower base elements consist of a hard foam core of expanded polystyrene with special mortar coating on both sides reinforced with glass fibre fabric and factory-made sealing on the upper side (exception TUB-COMBI MQ 300) with integrated and sealed horizontal floor drain.

**System components**

- **LUX ELEMENTS®-DRY-DB** is a sealing tape fleece backed on both sides, which is ideally suited for wall/floor connections and for the formation of wall corners.
  - width: 100 mm
  - thickness: approx. 0,6 mm
- **LUX ELEMENTS®-DRY-DBIE/AE** are deep drawn interior or exterior corners fleece backed on both sides, which are ideally suited for fast and secure formation of corner seals (suitable for LUX ELEMENTS®-DRY-DB).
- **LUX ELEMENTS®-DRY-ASK** is a single-component, water-impermeable, crack-bridging and flexible sealing compound.
- **LUX ELEMENTS®-COL-FLEX** is a flexible cement powder adhesive suitable for the thin-bed adhesion in accordance with DIN 18157 Part 1 of:
  - of ceramic tiles, panels and mosaic
  - fine stoneware
  - discolouration-resistant natural stone panels
  - ceramic coatings in pools
 LUX ELEMENTS®-COL-FLEX meets the C2TE-S1 requirements according to EN 12004 and EN 12002.

**Applications**

LUX ELEMENTS®-TUB-COMBI shower bases are provided with ceramic covering and can be used wherever building regulations stipulate barrier-free construction e.g. in homes for the elderly, disabled person's dwellings etc. and of course wherever the comfort and aesthetics of modern building methods are desirable. Thus our shower base  $\geq 120 \times 120$  cm and  $\geq 150 \times 150$  cm are certified according to the appropriate standards.



Herstellung einer Abdichtung im Verbund mit Fliesen- und Plattenbelägen unter Einsatz von LUX ELEMENTS®-TUB als Abdichtungssystem gemäß Bauregelleiste A Teil 2, Hfd. Nr. 2.50, Baumprüfungsstelle AZ



ETA-13/0238  
 LUX ELEMENTS®  
 WATERTIGHT SOLUTION  
 COMPONENT 3.2/8  
 www.luxelements.com  
 0799-CPD-130 - Nr. LEWS2013

The LUX ELEMENTS®-TUB-COMBI products are equivalent to the bonded panel-type sealing materials described in DIN 18534 Part 6. They are usable for the water action class W2-I as AIV-P. We would ask that you consult our Technical Department before using them in the water action class W3-I. LUX ELEMENTS®-TUB-COMBI shower bases (exception TUB-COMBI MQ 300) fulfil the requirements for the waterproofing of buildings in conjunction with tiles and pavings according to the building rules list A, part 2 number 2.50. The range of application refers to moisture exposure class A2 for directly exposed floor areas in rooms in which service or cleaning water is frequently or continuously used, such as e.g. transitional areas in swimming pools and shower units (public and private).

General Building Authority Approved Test Certificate No. P-AB/20802/05-2008 issued by Kiwa MPA Bautest GmbH Niederlassung tBU Greven.

Furthermore, the LUX ELEMENTS®-TUB-COMBI shower base elements are system components for the LUX ELEMENTS®-WATERTIGHT SOLUTION sealing system and fulfil the directive for the European Technical Approval for 'Watertight covering kits for wet room floors and or walls - Part 3: Kits based inherently on watertight boards', ETAG 022-3.

**Substrate**

– firm, load-bearing, clean and vibration-free mineral floors

**Recommended use**

The LUX ELEMENTS®-TUB-COMBI shower bases can be shortened. In all cases, a 50 mm wide margin must remain, measured from the edge of the installation frame. We would like to point out that LUX ELEMENTS®-TUB-COMBI shower bases which are not shortened all round with the same measurements then have a different external thickness due to the built-in slope, thus leading to an offset to the adjacent floor.

**Note also the enclosed assembly instructions: 'LUX ELEMENTS®-TUB/TUB-LINE Instructions for assembly'.**

### Covering materials

The LUX ELEMENTS®-TUB-COMBI shower bases were specially developed for coverings with ceramic covering materials. The ceramic covering takes on the function of the load distribution layer. The loads that can be anticipated in use are to be specified by the specialist planner. The covering must be selected according to the specified load.

Mosaic  $\geq 20 \times 20 \times 4$  mm with front-mount adhesive film can be used as the lining for both low exposures and heavier loads (e.g. wheelchair use of up to 200 kg) so long as a reaction resin is used for gluing and joining. If the size of the tiles is  $\geq 50 \times 50$  mm, tile adhesive of quality grade C2 can be used for gluing and a cementitious grout material for joining. Please take note of our General Building Authority Approved Test Certificate No. P-AB/20802/05-2008 from tBU GmbH and/or our European Technical Approval according to ETAG 022-3 when covering our shower base elements with surface materials. Ensure that the tiles/mosaic pieces have a sufficient breaking strength. The shower base element should not be subjected to loads greater than  $0.1 \text{ N/mm}^2$ .

LUX ELEMENTS®-TUB-COMBI shower bases should be protected between assembly and tiling processes from damage to the sealing. Even if subjected to incorrect use, e.g. stepladders for repair work, make sure load is evenly distributed.

### Technical Specifications

- Overall height of shower base element 80 mm [\*]
  - Floor drain frame: ABS plastic
  - Grate: stainless steel 1.4301, load class K3 (up to max. 300 kg)
  - Integrated slope from 80 mm to 68 mm [\*]. The design of descending gradients and directions belongs to planning services. Special designs are possible apart from the descending gradients stated here.
  - Compressive strength of  $0.1 \text{ N/mm}^2$
- \* standard except for TUB-COMBI MQ 300 (other thicknesses possible)

### ■ Secondary drainage

All LUX ELEMENTS®-TUB shower base elements are equipped with a second drainage level.

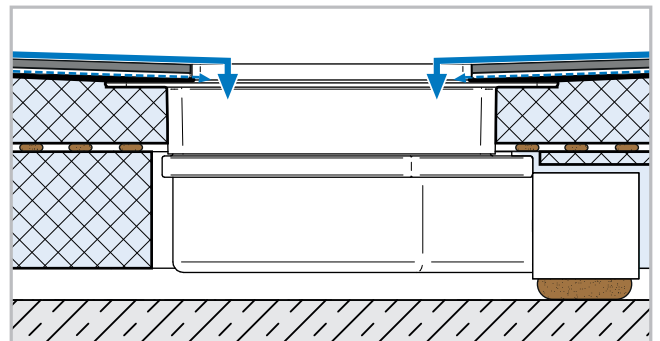

**LUX ELEMENTS®-TUB-COMBI Shower base elements**

Reviewed on: 01/2018  
 Replace DS from: 11/2015

■ **LUX ELEMENTS®-TUB-COMBI** (with integrated horizontal floor drain, sealing water height 22 mm)

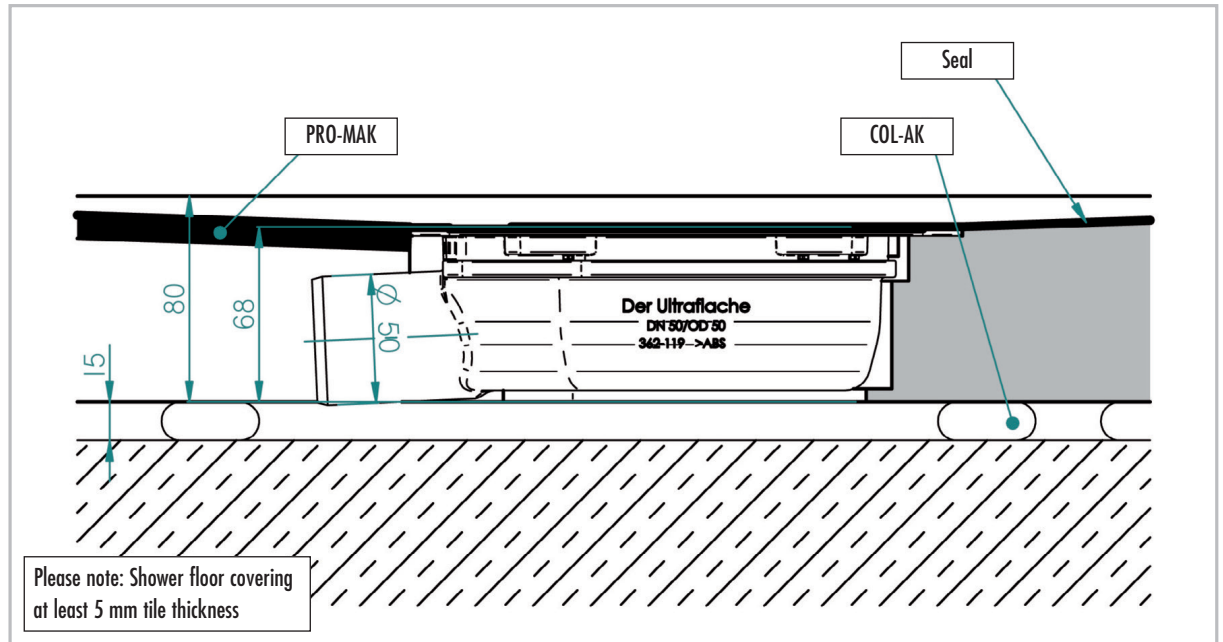

	Standard odour trap DN 50 vertical – Drain performance [l/s] in accordance with DIN EN 1253	Minimum covering thickness of shower base (tile + adhesive)
<b>TUB-COMBI + TUB-RA-S standard grate</b>	1.0	5 mm

The installation of a hair trap (TUB-BAZ HS) can reduce the drainage capacity by up to 0.3 l/s.  
 The installation of the Multistop (TUB-BAZ STOP) can increase the drainage capacity by up to 0.3 l/s.

■ **In general**

Please note that with flush with the floor shower bases, in the case of

- a low slope
- rough ceramics
- the lack of a shower enclosure
- unfavourable shower head placement
- high water pressure or high quantity of water (e.g. in the case of flood showers)

water can run out of the shower area or accumulate. Please refer to our planning aids and FAQ's for the planning of shower bases on our website ([www.luxelements.com](http://www.luxelements.com)).

■ **Accessories**

**LUX ELEMENTS®-TUB-BAZ STOP** is a retrofittable odour, foam and vermin barrier, which can be installed instead of a standard siphon trap.

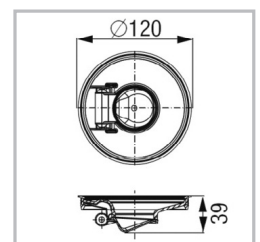

**LUX ELEMENTS®-TUB-COMBI Shower base elements**

Reviewed on: 01/2018  
 Replace DS from: 11/2015

**LUX ELEMENTS®-TUB-BAZ DN 50/40** is a DN 50 to DN 40 reducer with lip seal.



**TUB-BAZ DN 50/40**

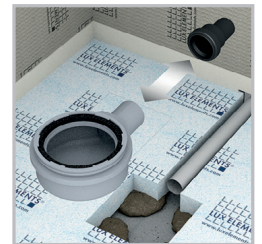

**LUX ELEMENTS®-TUB-BAZ BST** is an adapter from DN 50 to British Standard, made of PVC.



**TUB-BAZ BST**

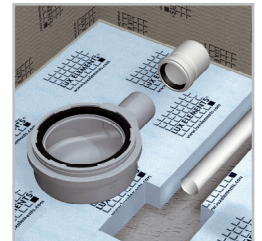

**LUX ELEMENTS®-TUB-BAZ HTK** replaces six traditional HT bends from 0 to 87 degrees. (see data sheet LUX ELEMENTS®-TUB-BAZ HTK)

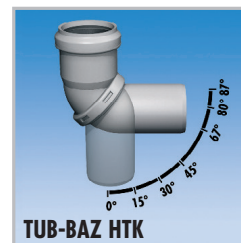

**TUB-BAZ HTK**

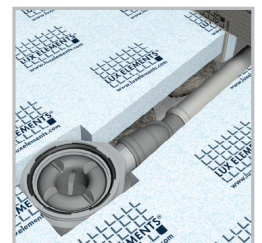

**LUX ELEMENTS®-TUB-TSM**, impact sound insulating mat, 1250 x 1250 x 6 mm. (see data sheet LUX ELEMENTS®-TUB-TSM)

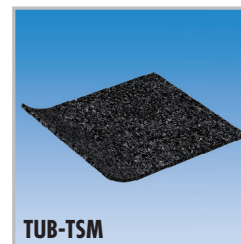

**TUB-TSM**

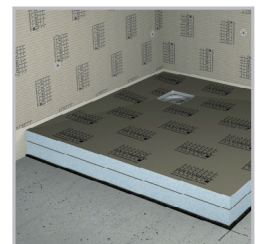

The relevant recommendations and guidelines, as well as DIN regulations, European standards and safety datasheets are to be observed. The recognised architectural and technical rules apply. We accept liability for the perfect quality of our products. Our processing recommendations are based upon trials and practical experience; they can, however, be no more than general instructions without assurance as to their quality, since we have no influence on the site conditions, on the execution of the work and the processing. With the issuing of this product datasheet previous versions cease to be valid.